

**“Henri Coandă”  
AIR FORCE ACADEMY**



**ROMANIA**

**“General M. R. Stefanik”  
ARMED FORCES ACADEMY**



**SLOVAK REPUBLIC**

# **AFASTUD 2017**

**THE 19<sup>th</sup> STUDENTS' INTERNATIONAL  
CONFERENCE**

*Communicating Across Cultures*



**April 6 – 8, 2017  
Brasov, Romania**

## Organizing Committee

Lt.Col. Associate Professor Eng. Laurian **GHERMAN**, PhD

Student Flavius Nicolae **BRICIU**

Student Daniel **BULAI**

Student Cosmin **RUSU**

Student Anamaria **ZUGRAVU**

Student Cosmin **DULUMAN**

Student Adrian **MARIN**

Student Răzvan **ROȘU**

Student Paul **POPA**

Student Ioana **GEANĂ**

Student Cristian **ANDREI**

Student Andrei **POPA**

Student Bogdan **ILEȘOI**

Student Vasile **SOLDANESCU**

Student Gabriel **GOBEAJĂ**

Student Mădălina **DONISAN**

Student Elena **VASILIU**

Student Andrei **NEGURĂ**

Student Silviu **DOBRESENCIUC**

Student Oana **TIVADAR**

Student Ștefan **CHIRIAC**

Student Claudiu **ARGYELAN**

Student Vlad **CHERAN**

Student Petrișor **RUSU**

Student Marius **POPA**

Student Vlad **SKOWRONSKI**

Student Maria **MUNTEANU**

Student Bogdan **BOGATU**

Student Daniel **FĂRCAȘ**

Student Radu **POENAR**

Student Cristian **MILEA**

Student Claudiu **BÎRCĂ**

Student Grigore **HANȚIG**

Student Tom **STOICA**

Student Lucian **IONEL**

Student Andrei **POPOVICI**

Student Andreea **MIHAI**

Student Denisa **BOLCHIȘ**

Col. Vasile **ȘANDRU**, PhD

Assistant Professor George-Cristian **CONSTANTINESCU**, PhD

Assistant Professor Cornel **ARAMĂ**, PhD

WO Sergiu **OBREJA**

Eng Mariana **GHINDĂOANU**

Eng Daniela **OBREJA**

Inf Adina **DOBRÎTOIU**

WO Marian **MIHALACHE**

WO Călin **DOBREAN**

WO Marius **TĂNASE**

## Scientific Committee

Lt.Col. Assoc Prof Eng. Laurian **GHERMAN**, PhD

„Henri Coanda” Air Force Academy, Brasov

Associate Professor Eng. **Marcel HAKAKAL**, PhD

Armed Forces Academy of General Milan Rastislav Štefánik, Slovakia

Associate Professor **Mária PETRUFOVÁ**, PhD

Armed Forces Academy of General Milan Rastislav Štefánik, Slovakia

Col. Vasile **ŞANDRU**, PhD

„Henri Coanda” Air Force Academy, Brasov

Assistant Professor George-Cristian **CONSTANTINESCU**, PhD

„Henri Coanda” Air Force Academy, Brasov

Maj Assistant Professor Cornel **ARAMĂ**, PhD

„Henri Coanda” Air Force Academy, Brasov

Lect Daniela **NAGY**, PhD

„Henri Coanda” Air Force Academy, Brasov

Maj Teaching Assistant **Daniel-Cornel ŞTEFĂNESCU**

„Henri Coanda” Air Force Academy, Brasov

Assistant Professor Vasile **PRISACARIU**, PhD

„Henri Coanda” Air Force Academy, Brasov

The editorial board claims no responsibility concerning the scientific contents of the published papers in this issue. The authors take the full responsibility for the contents. No part of this publication may be reproduced, partially or totally, without the prior written permission of the publishing board.

“Henri Coandă” Air Force Academy Publishing House  
ISSN, ISSN-L: 2360-0152

## C O N T E N T S

1.	<b><i>TWENTY-EIGHT YEARS OF DEMOCRACY; TWENTY-EIGHT YEARS OF SECURITY?</i></b> Adriana COMĂNOAIA	7
2.	<b><i>STEALTH HELICOPTER BOEING-SYKORSKY RAH-66 COMANCHE</i></b> George-Răzvan ȘUMĂLAN	13
3.	<b><i>A COMPARATIVE STUDY ON LONGITUDINAL STABILITY</i></b> Lucian CONSTANTIN, Cătălin EPURESCU	17
4.	<b><i>LEADERSHIP- TRIBUTE TO EMOTIONAL INTELLIGENCE</i></b> Ioana IONESCU	27
5.	<b><i>CONSIDERATIONS ABOUT DE RELATION BETWEEN MUSCULOSKELETAL FITNESS AND VITAMIN D AND PROTEIN INTAKE IN SPECIAL OPERATIONS FORCES WARRIORS</i></b> Iulia-Madalina STAICU	33
6.	<b><i>STUDY REGARDING RADAR CROSS SECTION OF UNMANNED AIRCRAFT</i></b> Larisa POPA	37
7.	<b><i>HUMAN-MACHINE INTERACTION</i></b> Gabriel-Dorian GLĂMAN	45
8.	<b><i>IMAGE OF A SOLDIERS PRESENTED BY MASS MEDIA COMPANIES AS A POSSIBLE THREAT FOR THE NATIONAL AND INTERNATIONAL SECURITY</i></b> Selda AHMEDOVA	53
9.	<b><i>AVIATION AND NOISE</i></b> Aleksandra ŚLIWIŃSKA, Andrzej ŚLIWIŃSKI	57
10.	<b><i>METHODS OF DIGITAL IMAGE PROCESSING</i></b> Ivan STEFANOV, Ivan DIMITROV	67
11.	<b><i>ASPECTS REGARDING INNOVATIVE SPACE THRUST SYSTEMS</i></b> Daniel Ion ULARU	73
12.	<b><i>THE INFLUENCE OF METEOROLOGICAL PHENOMENA ON AVIATION</i></b> Alexandra-Elena BOMBEA	79
13.	<b><i>OPTIMISM VERSUS PESSIMISM IN LEADERSHIP</i></b> Carmen-Elena BARANIUC	85

14.	<b><i>GAS TURBINE ENGINE COMPRESSORS</i></b> <b>Patricia-Marina PAUN</b>	<b>93</b>
15.	<b><i>CONSIDERATIONS ABOUT GEOGRAPHICAL INFORMATIONAL SYSTEMS</i></b> <b>Alexandru ANTAL , Adrian Andrei NEGURA</b>	<b>99</b>
16.	<b><i>GENERAL ASPECTS REGARDING INFORMATIONAL WARFARE</i></b> <b>Georgian - Cosmin CONSTANTIN</b>	<b>107</b>
17.	<b><i>PROPELLER OPERATING ISSUES IN SINGLE ENGINE AIRPLANES</i></b> <b>Nicolae Eduard ȘMALBERGHER</b>	<b>111</b>
18.	<b><i>HYDROGEN - FUTURISTIC FUEL FOR INTERNAL COMBUSTION ENGINES</i></b> <b>Marian VIJULIE, Larisa POPA</b>	<b>115</b>
19.	<b><i>PSYCHOLOGICAL COMPLEX IN THE MILITARY – SOURCES AND MANIFESTATIONS</i></b> <b>Ana-Maria MIHALEA</b>	<b>123</b>
20.	<b><i>MICROWAVE LANDING SYSTEM</i></b> <b>Adrian-Florin ARTENIE</b>	<b>129</b>

## TWENTY-EIGHT YEARS OF DEMOCRACY; TWENTY-EIGHT YEARS OF SECURITY?

**Adriana COMĂNOAIA**

"Henri Coanda" Air Force Academy, Brasov, Romania (comanoaia.adriana@gmail.com)

**Abstract:** *The National security strategy is a document with political and strategic relevance, and is fundamental in maintaining and defending the rights of its citizens. The analysis of such a document should bring forth threats, risks and vulnerabilities, as well as opportunities and advantages to national security. From a constitutional point of view, the president is not just the head of state, but also the person responsible with managing national security issues. The president must present a new national security strategy before parliament within 6 months of coming to power.*

*This project brings forth the vast transformations that the security strategy has undergone over the years in accordance to the development and adaptation of the Romanian society to the western politics. What did the last 27 years mean? For Romania it was a constant process of transition in which the main efforts were ensuring a permanent position within NATO and EU. The events after 9.11. transformed the world as we know it, the following wars and bombings shaped the modern society we know today.*

*From the results obtained, this project can be used as a starting point for a comparative research between Romania's and United State's security strategy.*

**Keywords:** *security strategy, analysis, transformation, NATO and EU.*

### 1. INTRODUCTION

Since 1989 Romania has suffered constant change which enabled the development of democratic institutions and the economy. The first project, The integrated security concept, was denied by parliament being accused of heavy conceptual errors and communist influences.

The first security strategy ever adopted was presented to parliament in June 1999 by president Emil Constantinescu. This document brought forth new terms, such as democratic stability and euro-atlantic integration (joining NATO and EU where defined as strategic objectives), guaranteeing fundamental rights to citizens and furthermore insisting upon the State's obligation towards its citizens.

The national security was no longer viewed as strictly a military issue, and it had received a multidimensional character through the introduction of economy, administration, public order, education and health. The shift in power in 2000, reelecting Ion Iliescu as president has meant postponing the previous strategy.

The new conception appeared in the Official Monitor in December 2001, being profoundly marked by the 9/11 terrorist acts. The fight against terrorism becomes a necessary component in overall phenomena of globalization, to which Romania joins without hesitation.

Amongst the objectives of the security strategy we can find: improving the economy, fighting against poverty and unemployment, developing civil society and the middle class, optimizing the national defense capabilities in accordance to NATO standards, harmonizing interethnic relationships, promoting the multicultural state, improving relationships with citizens beyond our borders, involving the civil society in solving national security issues. All in all this strategy suggests modernization and compliance with EU and NATO standards, and awareness to the overall globalization phenomena, as a potential risk and threat generator. The main issues remain social and economical, due to social tension and inequality, the fading quality of life, poverty, underdeveloped infrastructure, poor medical care and an underdeveloped transportation network. [9]

Beyond the general concepts defined and the acute need for change and modernization in all areas, the text adds nothing new, while the international security context is poorly analyzed.

## **2. SHAPING THE CONCEPT OF SECURITY**

On December 21<sup>st</sup> 2004, the new president, Traian Basescu sworn in before the joint chambers of the Romanian Parliament and on February 21<sup>st</sup> 2006 he presented in CSAT (the country's Supreme Defense Council) the draft of the National Security Strategy (the final version was adopted in April). It will be approved by Parliament and published in the Official Publication only after two years as a National Strategy of Defense.

One of the many controversies arising out of this strategy is the attempt to increase the role of CSAT by assigning it tasks that would usually belong to the Parliament (improvement of governance) and the Superior Council of Magistracy (the independence and functionality of justice). In the actual text is stated that in order to accomplish comprehensive different goals like improving governance, eradication of system related corruption, the independence and functioning of public and judiciary administration, the Supreme Council of National Defense (whose commander-in-chief is the President) will review periodically reports submitted on the issues and establish appropriate measures for achieving national security objectives. [10]

By extending the definition of security and CSAR functions through a permanent monitoring of the fulfillment of strategic objectives and the methods used in sector strategies, the president places himself, unconstitutionally, above the three branches of government and outside people's control. The President's intension to actively intervene in the governance process is clear from both the statement and its strategy to be a player and not a spectator.[14]

The strategy raises further serious doubts on the democratic nature by the presence of political evaluation of present government. As is stated in the strategy, corruption is a risk factor to national security identified since the beginning of the current administration which has created conditions for launching a comprehensive program of actions to eradicate corruption linked to political, legal and administrative power.

In terms of foreign policy it can be noted an absence of a clear vision towards European Integration as well as the absence of stating the role assumed by our country in this process. National security is seen through the spectrum of its international unit of active engagement in fighting risks and threats. The main concern seems to be the synchronization with or aligning to NATO/US's Security concepts. Talking about the Romanian-Moldavian relationship, the document enounces that there are two Romanian states, an attitude rather harmful that constructive.



The uncertainty of the concept of good governance, the deception of certain terms or the lack of explanation for others, the failure to clear specific situations which concern Romania's involvement in armed conflicts, transform the strategy into a tool for imposing an abusive regime, or at best a document of political propaganda. Romania should be prepared to use, together with allies and partners, all legal means –including those regarding the use of force- as a solution of last resort.

In December 2007 the collapse of Lehman Brothers marked the beginning of the global economic crisis. With high economic growth in the first half of 2008, Romania will not feel the collapse until 2009. Its effects were felt immediately, the exchange rate steady appreciated following austerity measures like reducing employees' salaries by 25% and increasing taxes by 5%.

Complained of having committed serious violations of the Constitution the President is suspended by a vote in Parliament in April 19<sup>th</sup>, 2007, termination which ceases after the May 19<sup>th</sup> referendum. Following the 2009 presidential elections Traian Basescu was re-elected for another term. On December the 6<sup>th</sup>, 2009 Traian Basescu sworn in before the two houses of parliament and in his speech proposed to modernize Romanian society, reform the state and pay a special attention to the mechanism which is responsible with coordinating institutions.

On June 22<sup>nd</sup> 2010, the president called in CSAT to ratify the National Strategy of Defense draft. The parliament postponed the vote for September the 1<sup>st</sup>. Adding journalistic work to potential threats to national security ("the phenomenon of media campaigns in order to denigrate state institutions by disseminating false information about their work, pressure from local trusts on political decisions to obtain economic benefits or in relation to state institutions" caused a major scandal in the press. Later on the president did not accept further negotiations to modify its content. The strategy received a positive opinion from the joint Commission of foreign policy in Parliament, but not from the joint Defense Committees. Thus, the National Defense Strategy from 2010 has not been endorsed by Parliament.

On July the 6<sup>th</sup> 2012 the president was hold off. The reason was that he wanted to intimidate and neutralize media through its addition to national security's threats. Obviously annoyed by criticism towards him and his relatives, the President has used his position as the Head of the Supreme Council of Defense and added pressure on media as following the acceptance of the strategy, the state institutions were required to act against media organisms, limiting the freedom of expression. Due to low turnout, the referendum was declared invalid, and in August 2012 the President returned to Cotroceni. [11]

A further analysis of the 2010 strategy brings up serious mistakes. Apparently our country took up the funding obligations for participating in the activities foreseen under the Individual Partnership and the costs required to support Romanian personnel operating within the political and military structures of the Alliance. The Individual Partnership Program was developed at a time when Romania was not a member of NATO. The new strategy kept the boundaries set in 2006 and ambiguous concepts like motivated and well-trained forces, good governance, and the country's reputation is now an element of strategic importance.

### 3. NEW DIMENSION OF SECURITY IN AN UNSTABLE GEOPOLITICAL CONTEXT

The armed intrusion of Russia in Ukraine (2014) , the attacks in France, Turkey, Iraq, Syria, Sinai, Egypt, Afghanistan, Cameroon, Indonesia, the refugee crisis and the influence of the increasing extremist group the Islamic State carve an international environment of instability and insecurity. The current security environment is characterized by dynamism, geopolitical instability and multiple uncertainties. In this context the National Strategy of Defense must respond to new security challenges.

The strategy was approved by Decision no.33 in the joint meeting of the Senate and Chamber of Deputies on June 23<sup>rd</sup> 2015, and then published in the Official Publication. The document is divided into four chapters; addressing security environment dispute is briefly, but actually covers pretty good the major events and trends. Some long waited and welcomed features are clarity of expression, lack of ambiguity and rigorous delimitation of concepts.

The focus is on separation a limited security system (which includes the defense dimension, the size of public order, intelligence, counterintelligence and security) and an extensive system (encompassing economic, energy, diplomatic management of crisis situations, education, health, social and demography). An important point for designing future position of the country in NATO and the EU is strategic credibility by predictability of continuity's foreign policy and security.

A Risk is the probability of eliciting an uncertain event with direct or indirect impact on national security. The vulnerabilities are the result of deficiencies or dysfunctions of the system that may be operated or may contribute to a threat or risk. It can be said, because of the numerous references in the text that the Russian Federation is a major threat to national security. A major player in the European and Euro-Atlantic is the Russian Federation. Its actions in the Black Sea region, violating international law, discussing the international order, preservation of frozen conflicts and annexation of Crimea have reminded NATO both fulfilling its mission fundamental, collective defense and validity of security arrangements concluded with Russia in the late twentieth century .The Russian Federation is trying to strengthen its regional power status in its actions affecting regional stability and European course of Ukraine, Republic of Moldova, and Georgia.

A difference from the previous strategies is the corruption on a lower position among vulnerabilities; on the 2015 strategy it appears on the last point. [12]

#### 4. CONCLUSIONS

The Security strategy of a country is the basic document governing the national defense planning. After more than two decades since the establishment of the rule of law we can say that Romania has a strategic point of view in a position very different from 1989. If by the year 1999 we are talking about the efforts to join NATO, the EU modernization and reform; the 2001 brings up issues of socio-economic, globalization and terrorism phenomena at high risk for national security. With Romania joining the Alliance, the policy used exclusive concepts aligned to NATO, bringing the risk of edge state in marginal state. I believe that, given that Russia is a very important player on the political and economic scene; the self-isolation and poor Romanian diplomatic relations made her a target state rather than a protected one under the tutelage of Washington-London-Bucharest axis. The last strategy that was adopted (2015) highlights Russia as a security threat. It seems that finally we, as a country, assume the role of partner.

#### REFERENCES

- [1] Adrian, Pop. *Strategia de Securitate Nationala - de la proiect la realitate* <http://www.revista22.ro/strategia-de-securitate-nationala----de-la-proiect-la-realitate-2844.html>
- [2] Administrația Prezidențială, Departamentul de Comunicare Publică, Declarația de presă a președintelui României, domnul Traian Băsescu, 26 noiembrie 2012. Răspunsul președintelui la criticile aduse de Ministrul Apărării Naționale, Corneliu Dobrițoiu, pentru modul în care a fost concepută Strategia Națională de Apărare 2010.
- [3] Administrația Prezidențială, Departamentul de Comunicare Publică, Discursul Președintelui României, Traian Băsescu, la ceremonia de depunere a jurământului în fața Camerelor reunite ale Parlamentului României (Palatul Parlamentului, 21 decembrie 2009), 21 decembrie 2009.
- [4] *Analiza Strategiei de Securitate a României*, Raport de analiza politica, Institutul "Ovidiu Sincal", București, 2006.
- [5] Cristina, Bogzeanu. *Balcanii de vest: studiu militar-economic*, Universitatea Națională de Apărare "Carol I", Centrul de Studii Strategice și de Apărare, București: Editura Universității Naționale de Apărare "Carol I", 2014.
- [6] Consiliul Suprem de Apărare al Țării, *Raportul CSAT privind activitatea desfășurată în anul 2007*, București, 2008.
- [7] Dorina Maria, Nastase. *Strategia nationala de securitate: de la aparare teritoriala, la securitate umana?* <http://www.revista22.ro/strategia-nationala-de-securitate-de-la-aparare-teritoriala-la-securitate-umana-2312.html>
- [8] Grupurile parlamentare PSD și PNL din Camera Deputaților și Senat, *Propunere de suspendare din funcție a Președintelui României, Traian Băsescu*, [http://www.cdep.ro/caseta/2012/07/06/hp12849\\_Suspendare.pdf](http://www.cdep.ro/caseta/2012/07/06/hp12849_Suspendare.pdf)
- [9] \*\*\* (2001). *STRATEGIE din 18 decembrie 2001 de securitate nationala a României*. Strategia de Securitate Națională 2001. MONITORUL OFICIAL nr. 822 din 20 decembrie 2001
- [10] \*\*\* (2008). *Strategia Națională de Apărare a Țării 2008*
- [11] \*\*\* (2010). *Strategia Națională de Apărare. Pentru o Românie care garantează securitatea și prosperitatea generațiilor viitoare*. București
- [12] \*\*\* (2015). *Strategia Națională de Apărare a Țării 2015*
- [13] \*\*\* *Cinci ani de criză economică. Ce s-a întâmplat cu economia românească în această perioadă*. <http://www.antena3.ro/economic/biz-news/cinci-ani-de-crisa-economica-ce-s-a-intamplat-cu-economia-romaneasca-in-aceasta-perioada-227987.html>

- [14] \*\*\* NewsKeeper - Băsescu: "Vreau să fiu un președinte-jucător, nu un președinte-spectator"  
<https://www.newskeeper.ro/articol?id=13EC548D6236F21876AD3FB1ED0B4FC1&data=2004-10-07>
- [15] \*\*\* Wikipedia. [https://ro.wikipedia.org/wiki/Traian\\_Basescu#cite\\_note-14](https://ro.wikipedia.org/wiki/Traian_Basescu#cite_note-14)

## STEALTH HELICOPTER BOEING-SYKORSKY RAH-66 COMANCHE

George-Răzvan ȘUMĂLAN

"Henri Coanda" Air Force Academy, Brasov, Romania (george.sumalan@gmail.com)

**Abstract:** *Helicopters are one of the most powerful weapon used on the battlefield. Its multiple capabilities performed on the field were improved during the last decades. As the technology evolved, the need for a stealth helicopter has become a number one priority for the military defense. The purpose of this research is to describe the first prototype of a stealth helicopter developed by U.S. Army in collaboration with Boeing-Sykorsky, but because of the low budget, the project was closed. Anyway, some helicopters nowadays use the technology developed under this program.*

**Keywords:** *stealth, helicopters, intelligence.*

### 1. HELICOPTERS BACKGROUND

During the past decades, a wide array of new technologies has entered the modern battlefield. New means and methods of warfare, such as cyber-attacks, armed drones or robots have been developed in order to be used on the battlefield. But nowadays the only thing that makes difference on the battlefield is information. The free flow of information within and between nation states is essential to a military force's ability to fight. We live in a highly connected world, where any information created could reach the entire world in less than 10 seconds.

A military helicopter is a helicopter that has numerous intelligence and military applications like medical evacuation (MEDEVAC), combat search and rescue (CSAR) or to support ground allies with firepower. Speaking about the role of a helicopters there are attack helicopters, transport helicopters and observation helicopter.

Attack helicopter main purpose is offer a close air support for the ground forces. The first modern attack helicopters were used in the Vietnam. Usually the crew is composed of two members, the pilot and the weapon officer.

Transport helicopter is mainly used to transport personnel and cargo for military operations. The main advantage is that helicopters don't require a runway for takeoff and landing, and also the cargo and personnel may also be picked up and dropped off using specialized devices.

The ability to hover in a fixed position at a certain altitude made helicopters ideal for observation and reconnaissance.

Over the last 50 years, helicopters have evolved from slow-moving multi-purpose support vehicles to fast-moving front line attack ships, but in the high tech wars of the future, speed is not enough, information is the key.

There are three elements that are critical to warfare, the ability for you to know more than the enemy, the ability to maneuver quickly around an enemy and gather more

information about them and the ability to provide precision firepower on the enemy position.

In future conflicts, after the F-22 Raptors and F-35 Joint Strike Fighters have cleared the way, surveillance and attack helicopters will support ground troops as they move in to secure the area.

Helicopters perform actions at low altitude, where the action is, but at such a low altitudes they are vulnerable to a wide assortment of ground to air weapons. There are two ways to counter this threat, inexpensive expendable unmanned helicopters and stealthy man helicopters. The first one will be used for surveillance and for gathering targeting information about the enemy position.

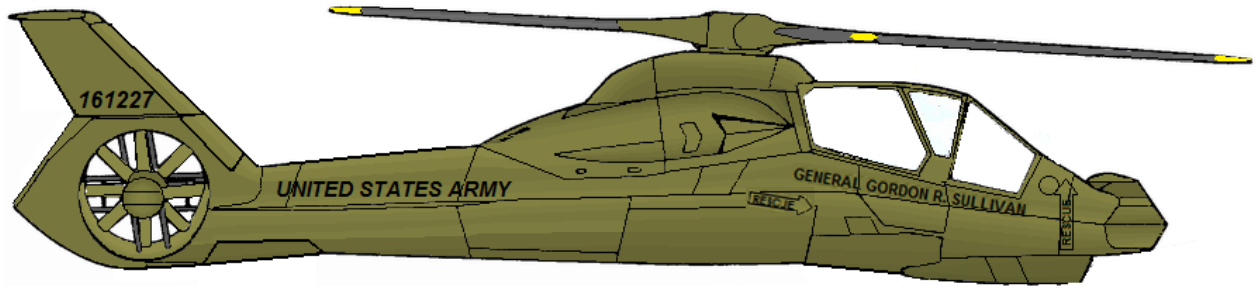

FIG. 1.1 Boeing-Sykorsky RAH-66 Comanche

## 2. STEALTH MILITARY TECHNOLOGY

A stealth aircraft is an aircraft specially designed to avoid detection of its presence. Achieving stealth on a helicopters is different from a fixed wing aircraft, you concern about signatures, radar reflexivity, infrared, noise, anything that can reveal the position of the aircraft. By stealth we refer on how detectable is an object on the radar screen. The airframe, or fundamental structure, of a helicopter can be made of metal or organic composite materials, but in order to achieve stealth, there is a special combination of composite material covered by a special layer of paint. The entire aircraft has no sharp, angled edges, every surface is curved in order to deflect radio waves. The curves are designed to bounce almost all radio waves away at an angle.

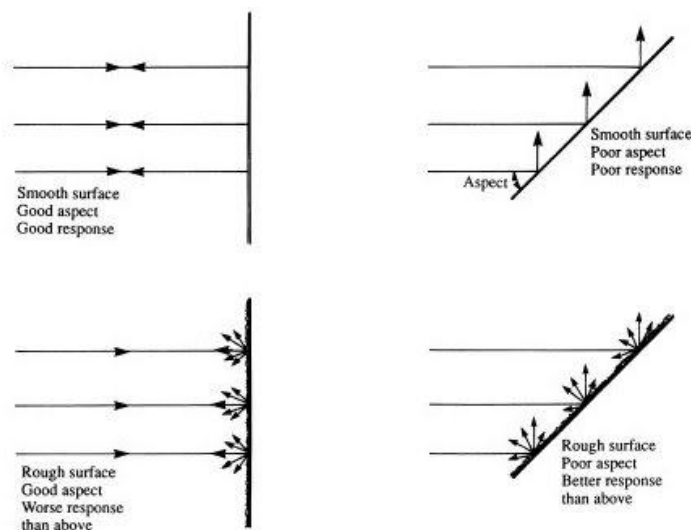

FIG. 2.1 The effects on target response of aspect and surface texture

The challenges for the engineers were to create a quiet helicopter with very few signatures and a small radar cross section. As a result of this challenge was Boeing-Sikorsky RAH-66 Comanche, which can defeat the radar threat and infrared missiles.

### 3. RAH-66 COMANCHE

The helicopter is powered by two LHTEC T800 turbo-shaft engines. Its fuselage made of composite materials was about 13 m., and has a range of 1.200 km. It was equipped with sophisticated systems intended to allow operations at night and in bad weather conditions.

RAH-66 has a great agility and handling on the battlefield. The five-blade rotor reduces dramatically the classic sound of a helicopter. The ground to air missile actually has a heat detector in order to reach the target but the Comanche's exhaust actually escapes through the tail, where is instantly dispersed by cool air from the rotor.

To defeat radar, Comanche uses stealth secrets first developed for F-117 Nighthawk, there are no right angles on its outer fuselage and all weapons are carried internally to help keep it stealthy shape. Once you get into the stealth part of it you get other superior advantage. Retractable landing gear and internal weapons increases the helicopter speed and handling.

The main role of the Comanche is to give commanders an overview of the battlefield by providing real time information and data and share that data with other Allied forces. Its main purpose is for reconnaissance but it will also be armed with a 22mm three-barrel gun, six AGM-114 Hellfire or twelve AIM-92 Stinger air-to-air, for self-defense situations.

Going over the general characteristic of this helicopter:

- Crew: 2;
- Length: 14.28 m;
- Rotor diameter: 11.90 m;
- Height: 3.37 m;
- Disc area: 111 m<sup>2</sup>;
- Empty weight: 4.218 kg;
- Useful load: 2.296 kg;
- Loaded weigh: 5.601 kg;
- Max. takeoff weight: 7.896 kg;
- Fuselage length: 13.20 m;
- Rotor systems: 5-bladed main rotor, 8-bladed fan-in-fin anti-torque system (FANTAIL);
- Powerplant: 2 x LHTEC T800-LHT-801 tuboshaft, 1.563 horsepower/each.

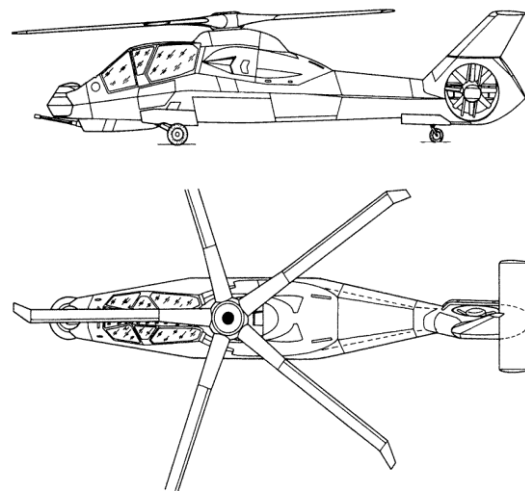

**FIG. 3.1** RAH-66 Side and front view

Performance:

- Maximum speed: 324 km/h;
- Cruise speed: 306 km/h;
- Range: 800 km on internal fuel;
- Rate of climb: 4.55 m/s.

#### Armament

- 1 x 20 mm XM301 three-barrel Gatling-style cannon mounted in a Turreted Gun System (capacity: 500 rounds);
- Internal bays: 6 x AGM-114 Hellfire air-to-ground missiles, or 12 x AIM-92 Stinger air-to-air missiles, or 24 x 2.75 in (70 mm) Hydra 70 air-to-ground rockets;
- Optional stub wings: 8 x Hellfires, 16 x Stingers, or 56 x Hydra 70 rockets.

#### 4. CLOSED PROJECT AND FUTURE DEVELOPMENT

Both, Apache and Black Hawk, will be gone by 2040. U.S.A. thought they could replace these with RAH-66, but because it is too expensive to build such a helicopter, they closed the project in 2004. It would have been one of the best 21<sup>st</sup> century equipment, with such small signatures, it could easily achieve any kind of mission. By 2004, Army decided to spend most of that money on UAV's instead.

Secretary of the Army for Acquisition said: *“just because a program is canceled doesn't mean all the lessons learned and the technologies we develop doesn't spiral into the next generation of the design...”*. So that means there are some helicopters nowadays that uses the same things that Comanche used.

And that was proven to be true. Indeed, some experts suggested that the helicopter used in the raid that killed Osama bin Laden incorporated some technologies developed under the Comanche program.

That's how the Stealth Black Hawk (also known as Silent Black Hawk) was born. Anyway we don't know for sure if it is real or not, Army didn't revealed the existence of this helicopter, but because one of the helicopter performed a crash during the raid, a piece of the tail remained on the ground. Experts said that it is different from the other Black Hawk because of the material it was made.



**FIG.4.1** Stealth Black Hawk

#### REFERENCES

- [1] RAH-66 Comanche- the self-Inflicted termination; Online documentation: [www.dtic.mil/cgi-bin/GetTRDoc?AD=ADA564477](http://www.dtic.mil/cgi-bin/GetTRDoc?AD=ADA564477)
- [2] RAH-66 Comanche- My Complete Aviation Database; Online documentation: [www.aviatorsdatabase.com/wp.../RAH-66-Comanche.pdf](http://www.aviatorsdatabase.com/wp.../RAH-66-Comanche.pdf)
- [3] Assessment of Crew Workload; Online documentation: [www.arl.army.mil/arlreports/2001/ARL-TN-183.pdf](http://www.arl.army.mil/arlreports/2001/ARL-TN-183.pdf)
- [4] Boeing-Sykorsky RAH-66 Comanche. Online documentation: [https://en.wikipedia.org/wiki/Boeing%E2%80%93Sikorsky\\_RAH-66\\_Comanche](https://en.wikipedia.org/wiki/Boeing%E2%80%93Sikorsky_RAH-66_Comanche)



## A COMPARATIVE STUDY ON LONGITUDINAL STABILITY

Lucian CONSTANTIN, Cătălin EPURESCU

Military Technical Academy of Bucharest, Romania

**Abstract:** *Longitudinal stability is a desirable feature for training aircrafts and can be undesirable for fighter jets. In this paper we study the geometric and aerodynamic characteristics of two different aircrafts with dissimilar roles. We emphasize the differences in stability through the values of their aerodynamic parameters.*

**Keywords:** *stability, longitudinal, Cessna, MiG, aerodynamics*

### 1. INTRODUCTION

In flight dynamics, we study the performance, stability and control of airplanes. In other words, it is the study of the orientation of the airplane with respect to the airflow – and the control of it. In order to provide the desired qualities, most of the airplanes use different control surfaces which are based on the same principles as those of a wing. This helps us to conduct a steady, balanced, flight.

This study will be focused on the longitudinal static stability. This is the stability of an aircraft in the longitudinal, or pitching plane under steady flight conditions. This characteristic is important in determining whether a human pilot will be able to control the aircraft in the longitudinal plane without requiring excessive attention or excessive strength. [1]

In order to make our calculations reality-based, we use as models two airplanes: *Cessna 150*, a two-seat tricycle gear general aviation airplane that was designed for flight training, touring and personal use; *MiG-29 Fulcrum*, a two-engine jet-fighter.

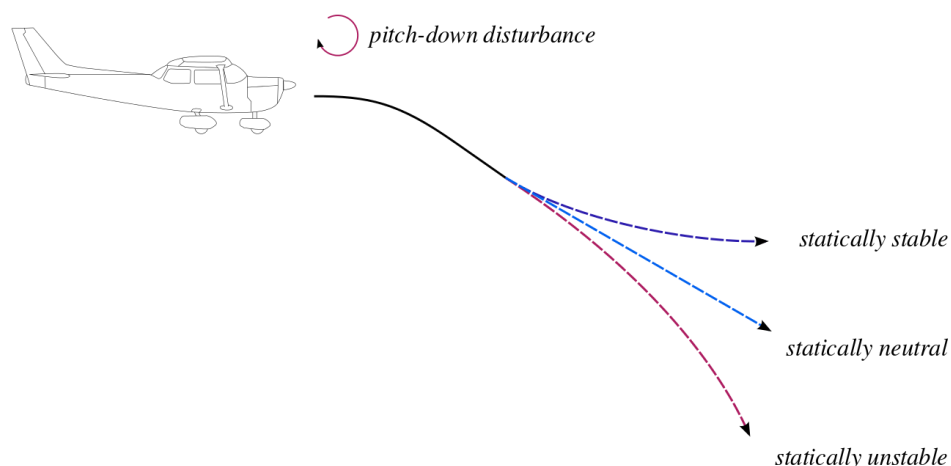

**FIG. 1** Representation of the concept of longitudinal stability

## 2. AIRCRAFTS OVERVIEW

We will conduct our calculations based on the Model 150 of Cessna and MiG-29 Fulcrum. The first is an airplane which presents good stability characteristics for its category, although inferior to those of the following models (i.e. Cessna 172, which is more stable longitudinally). The latter is designed to be unstable, to provide good maneuverability characteristics.

**Table 1** General characteristics

Characteristics/ Performance	Cessna 150	MiG-29
<b>Crew</b>	2	1
<b>Length</b>	7.29 m	17.37 m
<b>Height</b>	2.59 m	4.73 m
<b>Wing area</b>	15 m <sup>2</sup>	38 m <sup>2</sup>
<b>Wing span</b>	9.97 m	11.4 m
<b>Weight</b>	509 kg	11000 kg
<b>Maximum take-off weight</b>	726 kg	20000 kg
<b>Propulsion</b>	1 Continental O-200-A Engine with 4 pistons, 75kW power	2x Klimov RD-33 Turbofan (81.4 kN)
<b>Max. speed (sea level)</b>	202 km/h	2400 km/h
<b>Cruising speed</b>	152 km/h at 3000 m	770 km/h at 5000 m
<b>Service ceiling</b>	4300 m	18000 m
<b>Rate of climb</b>	3,4 m/s	109 m/s
<b>Range</b>	778 km	2100 km

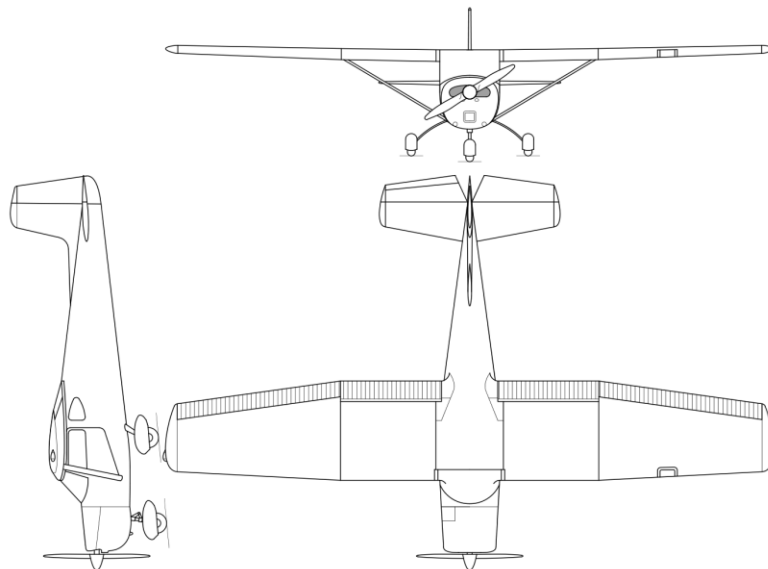

**FIG. 2 (a)** Cessna 150 in 3 views

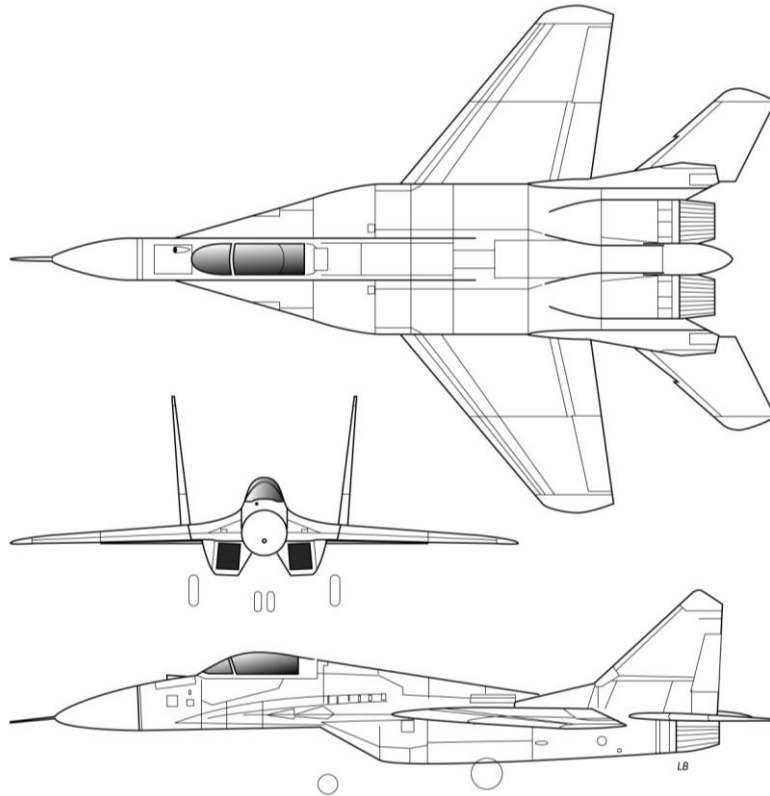

FIG. 2 (b) MiG-29 in 3 views

### 2.1 Geometrical parameters

The values which define the airplane's geometry play a key role in determining the flight characteristics of the airplane. Using the software Matlab, we have calculated and/or estimated some different dimensions which define the wing, empennage and the structure of the two airplanes. These values are presented in Table 2:

Table 2 Geometric parameters for Cessna 150 and MiG-29

Wing			Horizontal empennage				
Aircraft:	<i>Cessna</i>	<i>MiG</i>	Aircraft:	<i>Cessna</i>	<i>MiG</i>		
Root chord ( $c_b$ )	1.63 m	5.18 m	Root chord ( $c_{ba}$ )	1.11 m	2.4 m		
Tip chord ( $c_v$ )	1.13 m	1.69 m	Tip chord ( $c_{va}$ )	0.71 m	1.4 m		
Trapezoidal ratio ( $c_v/c_b$ )	0.69	0.32	Trapezoidal ratio ( $c_{va}/c_{ba}$ )	0.64	0.58		
Aspect ratio ( $\lambda$ )	6.62	3.42	Aspect ratio ( $\lambda$ )	1.5	3.7		
Mean chord ( $c_{med}$ )	1.39 m	3.73 m	Mean chord ( $c_{meda}$ )	0.92 m	1.94 m		
Leading edge sweep angle ( $\alpha$ )	2°	39.9°	Leading edge sweep	9°	40.7°		
Mean aerodynamic chord position positioning	$\bar{y}_c$	2.34	2.36	Mean aerodynamic chord position positioning	$\bar{y}_{ca}$	0.71	1.75
	$\bar{x}_c$	0.081	1.98		$\bar{x}_{ca}$	0.025	1.51

### 3. VARIATION OF LIFT WITH ANGLE OF ATTACK. AIR DEFLECTION AND AERODYNAMIC CENTER

The coefficient of lift contains complex dependencies between lift and wing geometry. Its dependence on the angle of attack is linear on a good portion of the domain of interest. For this domain, the linear dependency has the slope  $\frac{dC_z}{d\alpha}$ .

For the wing alone, separated from the fuselage, we can use the empirical formula:

$$C_{z\alpha-wing} = 2\pi \frac{\lambda}{2 + \sqrt{\lambda^2 \frac{1-M^2}{k^2} \left(1 + \frac{t^2}{1-M^2}\right) + 4}} \quad (1)$$

,the coefficient  $k$  for  $\lambda > 4$  is  $k = 1 + \frac{8,2-2,3\lambda-\lambda(0,22-0,153\lambda)}{100}$ , and

$$t = \tan \chi - \frac{2(1-r)}{(1+r)\lambda} \quad (2)$$

Plugging the values into Equation 1, we obtain the slope of the coefficient of lift.

We want to study the contribution of the fuselage and the horizontal empennage on the aerodynamic center. For this, we need some further information. The angle of attack of the horizontal empennage is smaller than that of the wing. Thus, the angle of attack of the wing is equal to the sum of that of the horizontal empennage and an angle of deflection of air,  $\varepsilon$ . The value of  $\varepsilon$  will be approximated by a Taylor series about  $\alpha = 0$ :

$$\varepsilon = \varepsilon|_{\alpha=0} + \frac{d\varepsilon}{d\alpha} \alpha \quad (3)$$

The value of  $\varepsilon|_{\alpha=0}$  is small and can be neglected. Thus, it is of interest the variation of the deflection angle with incidence. This has been found to be dependent on the following coefficients [2]:

$$\frac{d\varepsilon}{d\alpha} = 4,44 \left( K_\lambda K_r K_{mn} \sqrt{\cos \chi_{0,25}} \right)^{1,19} \frac{\partial C_z}{\partial \alpha} \frac{1}{\left( \frac{\partial C_z}{\partial \alpha} \right)_{\alpha=0}} \quad (4)$$

where

$$K_\lambda = \frac{1}{\lambda} - \frac{1}{1+\lambda^{1,7}}; K_r = \frac{10-3r}{7}; K_{mn} = \frac{1-\frac{m}{2}}{n^{0,888}} \quad (5)$$

with  $m = \frac{2Z_{ao}}{b}$  și  $n = \frac{2X_2}{b}$  and

$$\tan \chi_{0,25} = \tan \chi - \frac{4 \cdot 0,25 \cdot (1-r)}{\lambda(1+r)} \quad (6)$$

The parameters for the wing – horizontal empennage ensemble are:

- The distance from the leading edge of the wing to the leading edge of the horizontal empennage:  $X_1$ ;
- The distance from the 25% chord at wing root of the wing to 25% chord at wing root of the horizontal empennage:  $X_2 = X_1 + \frac{c_{bmsda}}{4} - \frac{c_b}{4}$ ;
- The distance from the leading edge at the mean aerodynamic chord to 25% of the root chord of the horizontal empennage:  $X_4 = X_1 + x_{cmsda} + \frac{c_{msda}}{4} - x_{cmsd}$ ;
- The distance from the trailing edge of the root of the wing to 25% of the root chord of the horizontal empennage:  $X_3 = X_4 + x_c - c_b$ .

Thus, we obtain the value of the deflection  $\frac{d\bar{\varepsilon}}{d\alpha}$ .

The longitudinal stability is intimately linked to the position of the aerodynamic center. For the estimation of the aerodynamic center of the wing – fuselage ensemble we calculate the two contributions separately:

$$(\bar{x}_{ca})_{wing-fuselage} = (\bar{x}_{ca})_{wing} + \Delta(\bar{x}_{ca})_{fuselage} \quad (7)$$

The position of the aerodynamic center of the wing is calculated as follows:

$$(\bar{x}_{ca})_{wing} = K_1 \left( \frac{x'_{ca}}{c_b} - K_2 \right) \quad (8)$$

For subsonic flight and moderate wing thickness, as it is our case, the value of the ratio  $\frac{x'_{ca}}{c_b}$  is estimated by using the following parameters:

$$\frac{\tan \chi}{\sqrt{1-M^2}} \text{ and } \lambda \tan \chi$$

Thus, we obtain a certain value for  $\frac{x'_{ca}}{c_b}$ . We obtain the position of the aerodynamic center of the wing  $(\bar{x}_{ca})_{wing}$ .

Regarding the coefficient  $\Delta(\bar{x}_{ca})_{fuselage}$  from Equation 7, we calculate it based on the theory of Munk, according to whom the fuselage of the airplane is divided in a series of elements of length  $\Delta x_i$  and width  $\Delta y_i$ , and each of these elements has its own contribution. These contributions are summed according to Equation 9:

$$\Delta(\bar{x}_{ca})_{fuselage} = -\frac{1}{2,92 \cdot S \cdot \bar{c}} \sum_{i=1}^N (\Delta y_i)^2 \left( \frac{d\bar{\varepsilon}}{d\alpha} \right)_i \Delta x_i \quad (9)$$

The aircraft has been modeled to scale using the CAD programs Catia and Solidworks, and the sections are presented in Figure 2:

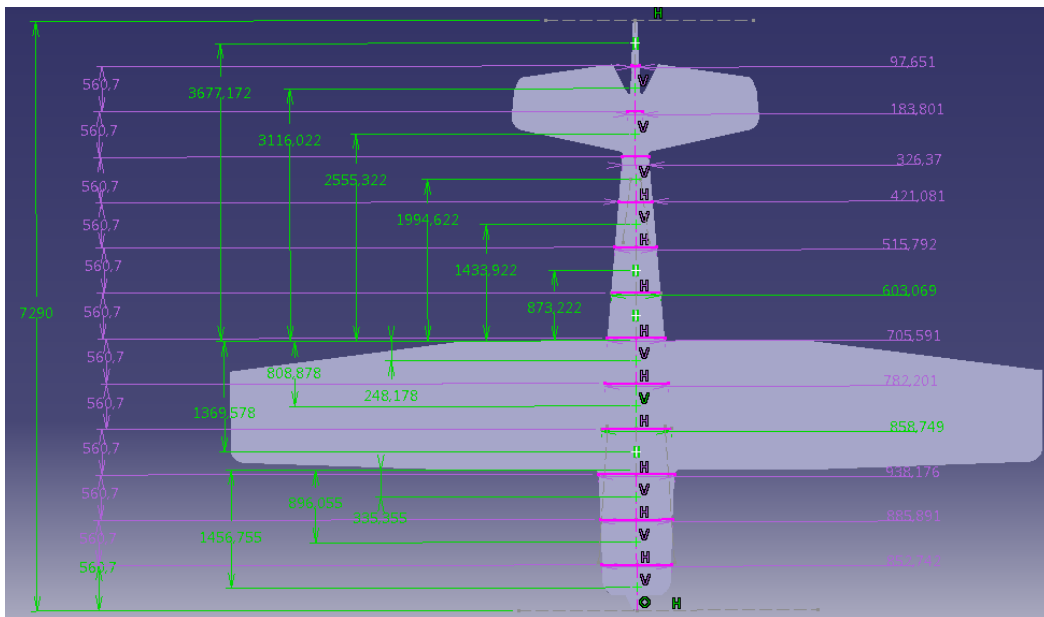

FIG. 3 (a) Sections used for calculating the fuselage's influence for Cessna 150

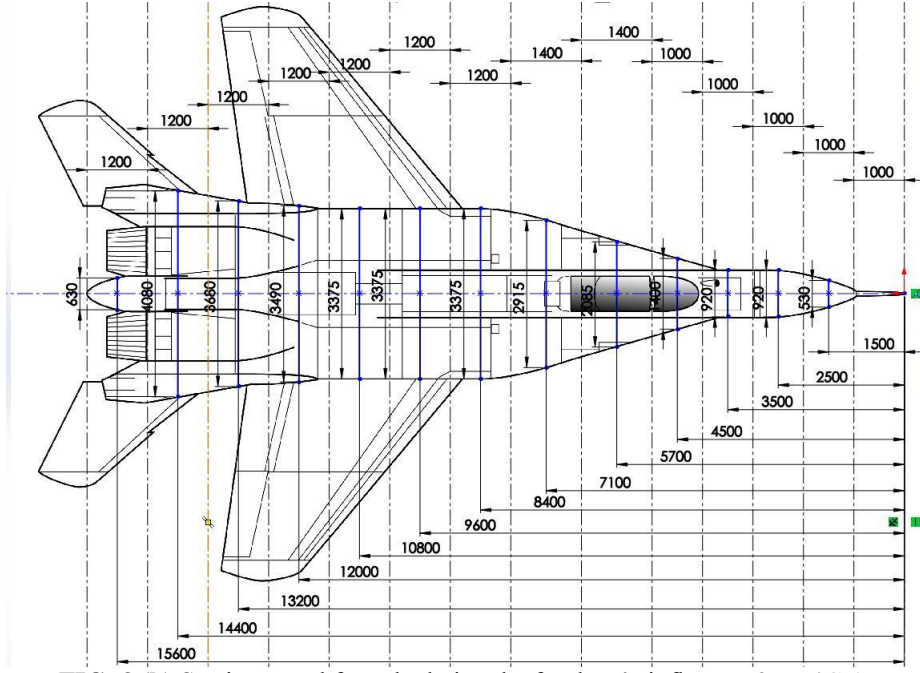

FIG. 3 (b) Sections used for calculating the fuselage's influence for MiG-29

We plug the data obtained by sectioning the fuselage in Equation 10:

$$\left(\frac{d\bar{\varepsilon}}{d\alpha}\right)_i = \frac{x_i}{X_3} \cdot \frac{d\varepsilon}{d\alpha} \Big|_{m=0} \quad (10)$$

where the value of  $\frac{d\varepsilon}{d\alpha} \Big|_{m=0}$  has been calculated beforehand.

Thus, we obtain the values presented in Table 3:

Table 3 Slope of medium deflection  $\frac{d\varepsilon}{d\alpha}$  for different sections

Sec.	1	2	3	4	5	6	7	8	9	10	11	12
Cessna	1.2	1.35	2.8	0,281	0,166	0,051	0,179	0,294	0,409	0,525	0,64	0,755
MIG	1.6	1.37	1.3	1.2	1.18	1.12	2.8	0.179	0.202	0.224	0.27	0.291

Summing, with Equation 9, we obtain  $\Delta(\bar{x}_{ca})_{fuselage}$ . Summing both contributions, we obtain  $(\bar{x}_{ca})_{wing-fuselage}$ .

We add the contribution of the horizontal ampenage too, to find the aerodynamic center of the whole airplane:

$$\bar{x}_{ca} = \frac{\bar{x}_{ca_{af}} + \frac{\frac{\partial C_{z_{AO}}}{\partial \alpha}}{\frac{\partial C_{z_{AF}}}{\partial \alpha}} \cdot \frac{q_{AO}}{q} \cdot \frac{A_{AO}}{A} \cdot \left(1 - \frac{d\varepsilon}{d\alpha}\right) \cdot \bar{x}_{ca_{AO}}}{1 + \frac{\frac{\partial C_{z_{AO}}}{\partial \alpha}}{\frac{\partial C_{z_{AF}}}{\partial \alpha}} \cdot \frac{q_{AO}}{q} \cdot \frac{A_{AO}}{A} \cdot \left(1 - \frac{d\varepsilon}{d\alpha}\right)} \quad (11)$$

According to Equation 8:

$$(\bar{x}_{ca})_{AO} = K_{1AO} \left( \frac{x'_{caAO}}{c_{bAO}} - K_{2AO} \right)$$

and we simply repeat the process, as we did for the wing. We obtain the position of the aerodynamic center of the whole plane  $\bar{x}_{ca}$  as fraction of the mean aerodynamic chord, measured from the apex of the wing.

**Table 4** Aerodynamic parameters for the two aircrafts

Parameter	Cessna 150	MiG-29
$\left(\frac{dC_z}{d\alpha}\right)_{wing}$	3.42	2.2
$\frac{d\varepsilon}{d\alpha}$	0.44	1.025
$(\bar{x}_{CA})_{wing}$	0.38	0.39
$\Delta(\bar{x}_{CA})_{fuselage}$	-0.046	-0.123
$(\bar{x}_{CA})_{wing-fuselage}$	0.33	0.266
$\bar{x}_{CA}$	0.51	0.255

Comparing the values obtained in Table 4, it can be shown that there are some significant differences. First of all, the wing's lift variation with incidence is steeper for the Cessna 150, showing that its wing is designed for a more efficient flight while the MiG's wing is designed for greater maneuverability in spite of efficiency. Second of all, the angle of deflection varies more abruptly with incidence in the case of the fighter showing different contribution in terms of the horizontal empennage in the two situations.

In what regards the wings' neutral points, we see that there is a certain similarity: both are located at approximately **39%** of mean aerodynamic chord, as measured from the leading edge. The contribution of the fuselage for the MiG is greater; both bring the aerodynamic center fore, but in different amounts. While for the Cessna the fuselage has negligible influence on lift, this is not the case for the MiG: the fuselage is designed to generate part of the lift, thus having a greater contribution on the position of the neutral point of the aircraft.

Comparing the positions of the aerodynamic center for the wing-fuselage assemble with those of the entire aircrafts we show that the horizontal empennage has a more important contribution in the case of the 150.

#### 4. LONGITUDINAL STATIC STABILITY

Longitudinal static stability represents the ability of the airplane to maintain its constant incidence of the steady, uniform flight. In order to see if the airplane is stable in this sense, we need to study the variation of the pitching moment or, for ease, of its non-dimensional coefficient. [3]

By convention, the positive moment increases the incidence and the negative moment decreases it.



FIG. 4 Variation of pitching moment with angle of attack

We see in Figure 4 that an essential condition for our airplane to be longitudinally stable is that the pitching moment should decrease when increasing angle of attack, and vice versa. [4] This is emphasized, mathematically, in Equation 12:

$$\frac{\partial C_m}{\partial \alpha} < 0 \quad (12)$$

We approximate the pitching moment coefficient using a Taylor expansion:

$$C_m(\alpha) = C_{m_0} + \frac{\partial C_m}{\partial \alpha} \cdot \alpha \quad (13)$$

Using the same procedure as before, we determine the variation of the lift with incidence for the horizontal empennage  $C_{z\alpha AO}$ . For the whole plane, we have

$$C_{z\alpha AF} = C_{z\alpha-wing} + C_{z\alpha AO} \cdot \frac{q_{AO}}{q} \cdot \frac{A_{AO}}{A} \cdot \left(1 - \frac{d\varepsilon}{d\alpha}\right) \quad (14)$$

Substituting the values we obtain  $C_{z\alpha AF}$ . The equation with which we calculate the longitudinal static stability coefficient is

$$C_{m_\alpha} = C_{z\alpha} \cdot (\bar{x}_{cg} - \bar{x}_{ca\_af}) - C_{z\alpha AO} \cdot \frac{q_{AO}}{q} \cdot \frac{A_{AO}}{A} \cdot \left(1 - \frac{d\varepsilon}{d\alpha}\right) \cdot (\bar{x}_{ca\_ao} - \bar{x}_{cg}) \quad (15)$$

We now need the position of the center of gravity of the airplane. We can obtain it in Catia using the model we have used for the deflection coefficient, but this procedure would take into account but the geometrical features of the airplane. We prefer to use the more precise data from the aircrafts' documentation:

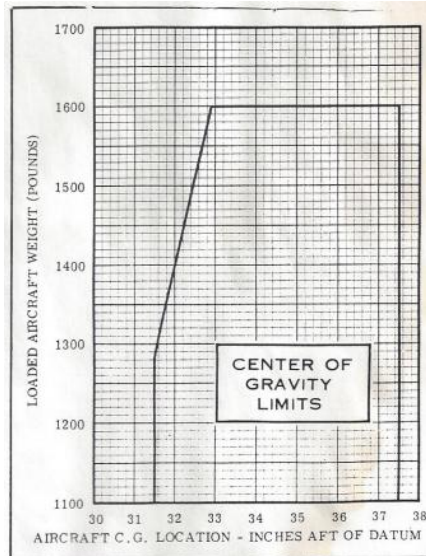

FIG. 5 Limits for the center of mass depending on loading, for Cessna 150



Taking into account the data from documentation and considering a moderate aircraft loading, we find the aircrafts' centers of mass.

Substituting in Equation 15, we obtain  $C_{m\alpha}$ .

Table 5 Stability parameters for the two aircrafts

Stability parameters	Cessna 150	MiG-29
$C_{z\alpha AO}$	2.19	2.07
$\bar{x}_{CG}$	0.32	0.29
$C_{m\alpha}$	-0.59	0.05

On the one hand, Cessna 150 is a training and general aviation airplane. Therefore, Cessna has to be stable by design. We see this fact mirrored in the value of  $C_{m\alpha}$  – it is negative, describing that the airplane is longitudinally stable.

On the other hand, the MiG is a fighter aircraft – it has to be highly maneuverable in order for the jet to have an ample and rapid response to the command, seen as a destabilizing factor. Consequently, it needs to be designed in a way that makes it unstable. Thus, we have calculated the longitudinal stability parameter to be positive: aerodynamically, it amplifies any external disturbance; the onboard computer acts as to maintain a steady flight under such conditions. This feature makes it a highly maneuverable aircraft.

## 5. CALCULATION OF BALANCE LIMITS

The position of the center of mass with respect to the neutral point represents an important factor in determining the stability of the airplane. Depending on it, we have three situations:

1. The center of mass is in front of the neutral point:  $C_{m\alpha} < 0$ , the plane is stable;
2. The center of mass is in the neutral point:  $C_{m\alpha} = 0$ , the plane is neutrally stable;
3. The center of mass is behind the neutral point:  $C_{m\alpha} > 0$ , the plane is unstable.

Every plane has a stability reserve. This means that the center of mass must be in front of the neutral point, but within certain limits. The anterior limit is calculated using Equation 16:

$$\bar{x}_{CGmin} = \bar{x}_{ca} - \frac{\Delta}{C_{z\alpha} \cdot C_{zmax}} \cdot \left( \frac{C_{z\alpha} \cdot C_{m0p}}{\Delta} - \delta_{pmin} \right) \quad (16)$$

where:

$$\begin{aligned} \bullet \Delta &= \begin{vmatrix} C_{z\alpha} & C_{z\delta p} \\ C_{m\alpha} & C_{m\delta p} \end{vmatrix} \\ \bullet \delta_{pmin} &= -\frac{C_{m\alpha} \cdot C_{zmax}}{\Delta} - \frac{C_{z\alpha} \cdot C_{m0p}}{\Delta} \\ C_{z\delta p} &= C_{z\alpha AO} \cdot \frac{q_{AO}}{q} \cdot \frac{A_{AO}}{A} \cdot \tau_{AO} \end{aligned} \quad (17)$$

The coefficient  $\tau_{AO}$  depends on the ratio between the horizontal stabilizer's chord and the chord of the wing.

Substituting in Equation 16, we obtain the inferior limit of stability. The calculated values are presented in Table 6.

**Table 6** Balance limits

Balance limits	Cessna 150	MiG-29
$\bar{x}_{CGmin}$	0.28	-0.24
$\bar{x}_{CGmax}$	0.51	0.26
$\bar{x}_{CG}$	0.32	0.29

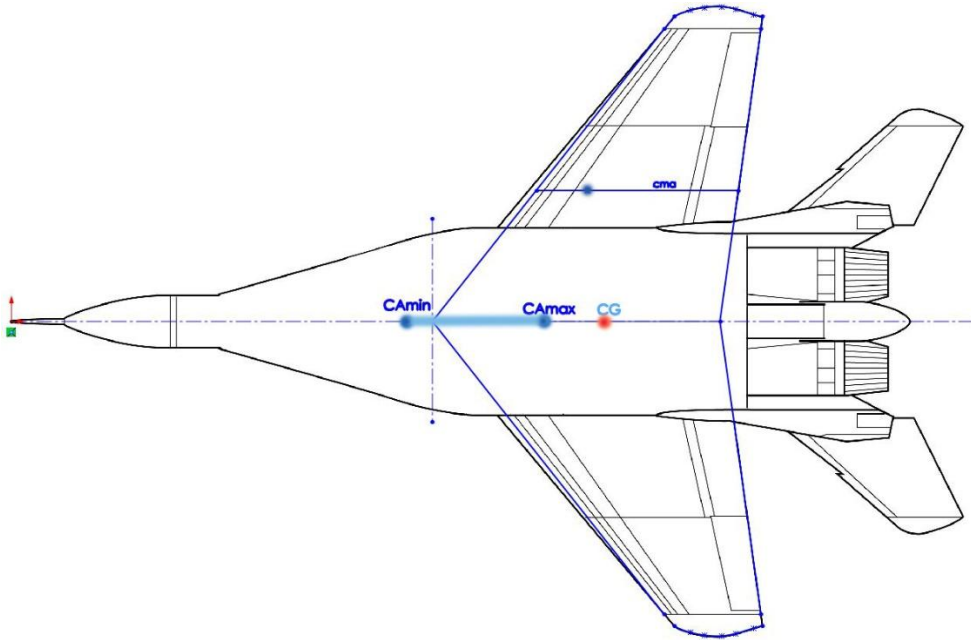

**FIG. 6** Balance limits for MiG-2

The situation is different for the two aircrafts, as can be seen from both the balance limits and the parameter of stability.

## 6. CONCLUSIONS

For the comparative analysis of longitudinal stability we have chosen two very different aircrafts, different in role, geometry and aerodynamics. For these two, the geometrical and aerodynamical features have been calculated or approximated based on data from documentation. We have seen significant differences in the variations of the coefficient of lift and angle of deflection with incidence. The contributions of the fuselage on the position of the aerodynamic center also differ very much, since the geometries are themselves so dissimilar.

After having performed the calculations we have reached the conclusion that Cessna 150 is a very stable aircraft, while MiG-29 is unstable, as it is desirable. Instability implies maneuverability, a quality we are looking for when designing a combat aircraft.

## REFERENCES

- [1] Clancy, L.J., *Aerodynamics*, Chapter 16, Pitman Publishing Limited, London. (1975)
- [2] Rotaru C., *Dinamica Zborului Avionului*.
- [3] Grigore I., *Mecanica Zborului Avionului*, Bucharest. (1987)
- [4] Hull, D. G., *Fundamentals of Airplane Flight Mechanics*, Springer

## LEADERSHIP- TRIBUTE TO EMOTIONAL INTELLIGENCE

Ioana IONESCU

"Henri Coanda" Air Force Academy, Brasov, Romania

***Abstract:** The following paper describes the necessary correlation that appears between the emotional side of human beings and the becoming of a true leader; it analyzes to what degree emotional intelligence influences leadership by explaining the resonant/ dissonant leadership styles, the functioning of an open-loop limbic system in the human brain and the way emotion is contagious and affects work performance.*

***Keywords:** leadership, emotional intelligence, work performance, human psychology*

### 1. INTRODUCTION

In trying to explain the impact leaders manifest on masses, psychology goes to great lengths with notions such as strategy, vision or triggering ideals, but the reality lies at a fundamental level, which is that leaders make use of emotion. Whatever leaders aim toward - creating strategies or mobilizing troops - their success does not depend on what they act on, but on how they do it. Even if they excel in any other aspect (organization, perseverance, authority, wealth etc), if leaders fail to channel emotion in the right direction, the outcome will never be as expected.

### 2. MASTERSHIP BASED ON EMOTIONAL INTELLIGENCE

The emotional responsibility of a leader is crucial, namely it is both an elementary function and the most important one. In any human group, the leader has the maximum capacity to influence emotion. If people's emotions are channeled towards enthusiasm, performance is born; if resent and anxiety are fuelled, people will lose efficacy and even efficiency. This fact indicates that the effects of emotional intelligence (E.I.) on leadership exceed the fulfillment of merely one task, but hover over the entire activity a group enterprise. Disciples expect an emotional bond with their master, they search for empathy. When leaders lead emotions in a positive direction, they obtain results. This effect is called "creating resonance". When leaders channel emotion towards a negative specter, they produce dissonance.

**2.1 Resonant leadership.** The word "resonance" refers to the property to intensify and prolong sound in a synchronous vibrational way. The human analogy to synchronic vibration produces when two people share the same ideas, prolonging the positive emotional concordance.

The impression of resonant leadership is given by the group of subordinates who, on making contact with the optimistic energy of their leader, vibrate accordingly. One of the main features of E.I. leadership is that the resonance amplifies the emotional impact of the leader. The better people resonate with each other, the more their interactions are less static and more fulfilling.

The binder that keeps people attached to a group and feeds their devotion towards the team they belong is the emotional load they experience within the group.

The efficacy with which leaders manage and channel this emotional baggage in assisting the group to reach its goal depends on how developed their E.I. is. Leaders who possess E.I. instinctively create resonance, to the point where they can project a grave state of mind, if needed, using empathy to connect to the emotional pattern the group depicts at a certain time. For example, if a situation which raised everybody's anger or sadness occurs, the E.I. leader not only empathizes with these emotions, but expresses them in the name of the group. This type of resonance favors synchronicity, as much as enthusiasm, because people have the feeling someone understands them and shows compassion.

Under the guidance of an E.I. leader, people share a common ground of understanding. They interchange ideas, learn from each other, make decisions based on collaboration and obtain finality to their actions. Between them an emotional bond is formed, which allows them to focus even in the midst of change or profound uncertainty, only because their leader inspires stability and trust. Even more important is that emotional bonds offer work true meaning. Sharing the joy of a work well done, on behalf of positive feelings, people build a reality which could not have come into existence to the merit of a single person.

**2.2 Dissonant leadership.** Dissonance, in its original musical sense, describes an unpleasant, unmelodic sound. Similarly, among human interactions, dissonance points towards the lack of harmony. Dissonant leadership gives birth to groups who reside in an emotionally uncomfortable state, in which the members constantly feel they live on a false note.

There are many types of dissonant leaders, who are not only incapable of empathy (they are not synchronized with the group) but they also transmit emotional vibes which resonate in a negative range. There is no deliberate intent behind discordant behavior. Being destitute of the main E.I. abilities prevents their approach to any matter to serve its primary purpose: the cohesion of the group. Dissonant leaders may vary to the extremes, from abusive tyrants who spit offensive language and humiliate, to apparently harmless individuals who are so inefficient and negative that they drive others plainly mad- they compulsively create miserable working environments, having no clue how destructive they are.

To an extent, dissonant leaders may give the impression of short term efficiency - i.e. they obtain the long coveted promotion - but the toxicity they leave behind them contradicts the initial success. Regardless of their managerial activity, their sole legacy is apathy, fury and resentment- it is the case of people everybody hates to work for, but cannot explain why. If leaders signal negative emotions, the final product will be people's exhaustion. Such "superiors" issue their own emotions - corrosive ones, especially chronic fury and anxiety, or the feeling of unworthiness - hijacking attention from the ongoing task and receiving nothing.

Emotional inconsistency does not only erode mental functions but prevents humans from accessing their own E.I.- i.e. people who are mad have difficulties in interpreting correctly other's emotions or reactions - their empathy diminishes and thus, their social skills are affected. Another aspect would be that the emotions people experience during work reflect the authentic quality of their professional life. Common-sense suggests people who feel bad at work will put little effort in doing it; thus, leaders who signal negative moods among subordinates are detrimental to business.

**2.3 The open-loop limbic system.** The reason why a leader's attitude (not as much what he does, but the "hows" he chooses to do it) matters to such an extent is found in the human brain's functioning - the nature of an open-loop limbic system (where the primary emotional centers reside). A closed-loop system, as the circulatory system, self-regulates. People do not influence each other's circulatory systems. An open-loop system depends on external sources to regulate itself. In other words, human relies on other humans to gain emotional stability. The open-loop nature of the limbic system in the human brain is a success on the evolutionary scale, permitting humans to save each other emotionally - i.e. it permits a mother to hush her crying baby.

Despite the sophisticated civilization people have created, the open-loop limbic principle is as primitive and viable as ever. Scientists describe the open-loop system as an interpersonal limbic adjustment, through which a person transmits emotional signals that can modify hormonal levels, cardiovascular functions and even immunity functions within the body of a different person. That is the way lovers are capable of stimulating each others' brains to secrete amounts of oxytocin, which create a pleasant feeling of affection. In all aspects of life, not only love, but human physiology interferes and emotions automatically switch to the affective pattern of the person with the highest level of emotional influence. Through the open-loop nature of the limbic system, the interdependency of humans is understood and implicitly, the way waves of emotions are mutually shared.

Even if the open-loop limbic system operates in human life, it is rarely acknowledged, because it seems impalpable, unpredictable; but it is childish to assume humans as being merely robots. Researchers have observed how emotions tend to spread in an unstoppable manner, even when the whole interaction is non-verbal. For example, if three strangers stand face to face in silence, for several minutes, the one who is more emotionally expressive will share his emotional state with the others, without uttering a single word. The same phenomenon takes place in the office, in the briefing room or workplace. People working in groups sense the waves of energy which are most persistent or powerful and subconsciously align to them, sharing from stress and anxiety to calmness or euphoria. It is only the physiology of emotions.

**2.4 Neuro-activity.** Leaders need a sufficiently developed intellect to raise to the specific tasks the challenges and responsibilities of a man of power imply. Leaders equipped with the ability to make decisions, who favor analytical and conceptual thinking are more valuable. It is considered that intelligence and clear thinking are the primary qualities that designate leaders.

However, intellect proves to be only a part of the whole story. The duty of a leader is to make his vision come into existence, by motivating, inspiring, persuading – by creating resonance. As Albert Einstein stated - "Don't make a deity out of intellect. It has powerful muscles, but no personality. It can't lead, it can only serve."

The neuronal systems responsible for intellect and emotions are separate, but strongly bounded. The cerebral circuits that connect thought and feeling are the basis of E.I. leadership. Although the working environment people live nowadays in values excessively the intellect drained of emotion, emotions are more powerful than intellect. In the crucial moments of human life, the emotional centers - the limbic brain takes over the entire brain.

The emotional impulses follow complicated paths, starting from the tensile nucleus at the base of the brain to the prefrontal area at the back of the forehead, where the executive centers lie. The prefrontal area receives and analyzes information from all over the brain, then makes decisions based on it.

The prefrontal area has the ultimate word over emotional impulses- making sure the human's response in a situation is the efficient one- i.e. if somebody is angry it prevents the person from starting a fight if unnecessary. In the absence of such control, the result would be an action on behalf of the impulse received by the tensile nucleus, resulting in a primitive, uncontrolled behavior. The prefrontal region supervises emotional impulses.

The dialogue between the neurons in the emotional centers and those in the prefrontal area takes place on a neurological highway, on which thought and feeling race. The two are never alone, but interwoven. The E.I. competences, vital in leadership, depend on the good functioning of prefrontal- limbic circuits. Studies conducted on neuro-damaged patients, who suffered injuries on the prefrontal- limbic areas, confirm that even though their cognitive abilities such as intelligence, technical or organizational thinking, general knowledge were intact, emotional aspects (empathy, compassion, motivation or the ability to feel happiness/sadness) were affected. These individuals were unable of normal social interaction, even though they were clever enough.

Biologically speaking, the art of resonant leadership implies a correlation between intellect and the right emotion in a given situation.

### **3. EMOTIONAL CONTAGION IN LEADERSHIP**

Permanent interference of the limbic systems between members of a group creates an "emotional soup", at which each individual contributes with its own ingredient. But the leader adds the essential spice- due to the implacable reality that governs the hierarchical working system: all eyes are on him. People pick their emotional clues from the top of the pyramid. Even when the boss is not as visible- working from behind closed doors- his attitude influences the mood of his direct subordinates and a domino effect propels in the entire emotional climate of the working place.

Close observation of working groups revealed several ways leaders manage to play the crucial role in deciding the common mood. Usually, leaders talk more than anyone else and their words are listened to with the most attention. Also, leaders are the first to express their opinion on a subject and when observations are added, they usually refer to what the leader, and not anyone else, said. As the leader's perspective has a special meaning to the group, they offer the way to interpret and thus the way to react emotionally to a situation. But the impact on emotion is not influenced only by what the leader has to say. Due to studies, even when the leader did not talk, he was attentively watched by the group, When a collective question was asked, the eyes were on the leader to observe his reaction. Members of the group consider the emotional reaction of the leader is the right one and consequently mould their own emotional response to it- especially in an ambiguous situation, in which different members react differently. Somehow, the leader fixes the emotional standard.

Not all "official" leaders are necessarily emotional leaders, too. When a certain leader does not inspire credibility, people search for emotional guidance at a person who inspires trust and respect. Leaders can choose to be scarce with compliments; they can contribute with constructive or destructive criticism and acknowledge or ignore the needs of the members. The behavior they choose depends on them alone.

The ones who choose fairly will succeed in offering guidance (so subordinates see clearly where their effort is headed to), encouraging flexibility and offering people the liberty to use their best assets to finish their work. True leaders allow people to be their own selves, but most of all, they formulate the group's mission in a way that conveys meaning to the smallest effort a member makes towards fulfilling it.

The easiness with which leaders' emotional state becomes contagious depends on paralinguistic clues- the mimics of the face, the tone of the voice and all nonverbal gestures. The capacity to transmit their state does not depend on theatrical maneuvers; since people closely observe them, even subtle emotional expressions influence. But sincerity and clarity of thought fuel leaders' genuine behavior, which becomes appealing only if it is not a lie or a simple act.

#### **4. EMOTIONS AND WORK EFFICIENCY**

Although emotions and moods may seem professionally irrelevant, they have real consequences on the ongoing working process. The moderate anxiety the leader inspires may point to the importance or delicacy of a certain task, implying an increased attention be directed towards it. Truly, a serious disposition can be of real help when a risky situation is analyzed- too much optimism may lead to ignoring potential dangers. An unexpected wave of anger may center attention towards an urgent problem, redirecting the whole energy of the group.

A moderate dose of anxiety (i.e. the approach of a dead-line) may contribute to the focus of attention and energy, but a prolonged state of worry can sabotage the relationship between leader and subordinates and can affect work performance, diminishing the brain's ability to process information and act accordingly (chronic stress destroys concentration). A good laugh or an optimistic disposition, on the other hand, amplifies the neuronal abilities crucial for the development of an activity in normal conditions.

Good moods as much as bad ones tend to endure in time, partly because they influence perceptions and memories: when people are in a good mood, they see the positive side and if they are in a bad mood, they linger on the negative aspects. Besides this deformity of perception, it takes hours before the hormonal infusion provoked by stress or other strong emotions in a person's body begins to wear off. This is why a difficult relationship with the boss may give a subordinate sleepless night. He becomes the prisoner of his own distress, his body is incapable to calm down and thus, he is unable to work properly.

Emotional intelligence is no longer a personal aspect, but a key factor in the success of an organization; it is the secret ingredient by which management becomes leadership. The emotional intelligence abilities contribute to carving the emotional impact of a leader.

## 5. REFERENCES

- [1] Steven J. Stein, Howard E. Book, *Forța inteligenței emotionale*, Alfa, 2003
- [2] Manfred Kets de Vries, *Leadership, Codex*, 2003
- [3] Peter Koestenbaum, *Liderul- fata ascunsa a excelenței*, Curtea Veche, 2006
- [4] Daniela Belu, *Bazele managementului*, Academia Fortelor Aeriene “Henri Coanda”, 2012



## CONSIDERATIONS ABOUT DE RELATION BETWEEN MUSCULOSKELETAL FITNESS AND VITAMIN D AND PROTEIN INTAKE IN SPECIAL OPERATIONS FORCES WARRIORS

Iulia-Madalina STAICU

Institute for Military Medicine, Bucharest, Romania (iulia.staicu20@gmail.com)

**Motto:** *“The Special Operations Forces operator is the primary weapons platform. There is an imperative to extend the operational life and maximize the battlefield performance of the operator. Nutrition is a critical component in human performance strategies.”* CAPT “Pete” Van Hooser, Former Commodore, CNSWG-Two

**Abstract:** *Special Operations Forces (SOF) training, combat, and contingency operations are unique and demanding. Like performance athletes, the musculoskeletal system fitness of these warriors is vital to accomplish their missions. The important element for a strong skeleton is the vitamin D intake and for a fit muscular system important is the protein intake. We made a search on the available medical literature in databases (Medline, Wiley, Science Direct), and we selected articles published since 2013 to 2016. Search terms included: military, diet, military personnel, nutrition, fitness, musculoskeletal, protein, vitamin D. 12 abstracts and/or articles were selected. We extracted from them different points of view of different authors and tried to summarize which is the ideal Vitamin D and protein intake in special operations forces warriors.*

**Keywords:** *military, diet, military personnel, nutrition, musculoskeletal, protein, vitamin D*

### 1. INTRODUCTION

Special Operations Forces (SOF) are “Warrior Athletes,” the ultimate athlete. The physical and mental demands imposed by SOF training and missions require appropriate nutritional habits and interventions so that, under the most rigorous conditions, performance is optimized, and health is preserved <sup>[1]</sup>.

### 2. THE 10 COMMANDMENTS OF NUTRITION: 2014

The first 10 Commandments of Nutrition is a short publication of the US Special Operations Command. These 10 very simple advices are useful not only for special forces soldier but also for all military personnel to achieve their goals.

- a. Do not believe anything you read or hear about nutrition that comes from someone trying to sell you something.
- b. Read the “nutrition facts” label for all packaged foods to determine energy, nutrient, and vitamin content.
- c. Most Americans do not need dietary supplements.
- d. Beware of protein and amino acid supplements—just under 1g of protein per pound of body weight per day is the maximum recommended protein intake.

- e. The types of fat in the diet are more important than the amount, but fat intake should be limited.
- f. During periods of prolonged, intense exercise, replace sweat loss by drinking up to 1.5 quarts of a carbohydrate/electrolyte fluid every hour.
- g. Consume a snack containing carbohydrates (CHO) and some protein within 45 to 60 minutes after strenuous exercise lasting 90 minutes or longer, and be sure to rehydrate.
- h. Eat fresh fruits, fresh vegetables, and high-fiber foods daily.
- i. The most common nutritional problem in this country is too much nutrition.
- j. Short-term weight reduction diets are generally useless and occasionally dangerous. Long-term changes in your eating and exercise habits are the only way to achieve lasting weight modifications <sup>[2]</sup>.

### **3. PROTEINS**

Proteins are the one of the main sources of energy for the human body beside CHO and fat. All of them are called “macronutrients”. While CHO and fat consist of carbon, oxygen and hydrogen, proteins consist of all these atoms, plus nitrogen, which is essential for life. Proteins are made up of amino acids—small building blocks hooked together in various orders. Although over 20 different amino acids are part of our body, only 10 are “essential amino acids” (EAA) because our body cannot make them; they must be obtained from protein in the diet. Failure to obtain enough of the 10 EAA, in the right balance, may result in degradation of other proteins, such as muscle, to obtain the one EAA that is needed. The main functions of protein are: muscle contraction, formation of muscle and other tissues, direct energy production, repair of injuries, transport fats, vitamins and minerals around the body and structural roles for every part of the body.

### **4. ENERGY AND PROTEIN INTAKE REQUIREMENTS FOR SOF SOLDIERS**

Study showed that the energy expenditure (and corresponding energy requirement) for SOF soldiers conducting military training exceed that of the average soldiers ( $16,334 \pm 2180 \text{ kJ}\cdot\text{day}^{-1}$ ) instead  $13,598 \text{ kJ}\cdot\text{day}^{-1}$ ) <sup>[3]</sup>.

As we already mentioned, proteins are a component for refueling energy expenditure. Protein are essential for building and repairing body tissues; however, excess protein is converted to fat. The timing of nutrient delivery is critical to sustaining performance. The Refueling Interval (RFI) is the 45 minutes after finishing a workout. Adding protein to the recovery meal will help stimulate protein synthesis to assist in rebuilding muscle (anabolism).

For exercise longer than 90 minutes, warriors need to consume beside CHO, 12 grams of protein as food or drink immediately during the RFI. Snacks for night operations should include foods low in CHO and high in protein. All operators require no more than 1 gram of protein per pound of body weight per day. In addition, is better to use “real” foods instead of supplements and protein powders.

Also, the intake of protein represents a key part of muscle proteostasis (muscle protein synthesis (MPS) and muscle protein breakdown (MPB)), with the best current advice for the warfighter being an intake of a minimum of 20 g (with each individuals own recommendation ranging from ;20 to 40 g) of EAA-enriched protein every ;4–5 h during the daytime, including before bedtime. For the warfighter, the intake of protein also plays a key role in both exercise adaptation and in functional recovery from acute exercise bouts, and is subject to similar timing and quantity recommendations as the nonexercise state.

Finally, the intake of protein in close proximity to exercise, whether just before or just after, is likely an optimal nutritional strategy for a warfighter to adopt <sup>[4]</sup>. Further more it is sure that, when prolonged conditions of negative energy balance are encountered, routine protein supplementation may serve to minimize muscle losses and offset performance detriments during periods of operational stress <sup>[5]</sup>.

Special operations often operate in a negative energy balance in stressful and demanding conditions with little opportunity for rest or recovery. Existing evidence points to the advantages of greater protein intake are presented in table 1.

Table 1. Advantages of greater protein intake

- 1) Increased protein intake during periods of negative energy balance improves maintenance of lean body mass and blood glucose availability.
- 2) Operations at altitude result in negative energy balance, which would benefit from increased protein intake, although adequate ingestion remains a challenge due to alterations in nutrient absorption.
- 3) Congestion of protein in a mixed-supplement format imparts performance advantages to both endurance and strength outcomes, as well as specialized motor skills.
- 4) Increased protein intake confers benefits on physiologic and psychological recovery. Protein consumption before sleep stimulates muscle and whole-body anabolism and translates to improved performance, muscle recovery, and psychological well-being.
- 5) A small increase in chronic protein ingestion improves recovery from muscle damage/surgery and rate of recovery of muscle strength <sup>[6]</sup>.

In addition, attention must be paid to protein quality, providing the highest quality possible to maximize benefit, as well as including nutrient-dense protein sources to provide adequate quantities of other nutrients. If included in field rations, protein sources will also need to have good food stability that will allow products to be functional in extremes of climate such as those encountered in military scenarios <sup>[7]</sup>.

Regarding protein supplements (PS) studies showed that most war fighters consuming a normal, ad libitum diet meet their energy and the recommended dietary protein requirements without the need for consumption of PSs <sup>[8]</sup>.

There are no information regarding the exacerbation of the severe operational stress effects because of aging and whether PSs are an effective countermeasure to the physiological consequences of aging. Also it is mandatory to determine in future studies if there is a benefit of higher protein intake in individuals who are in energy balance and the effects of protein supplementation with regard to healthy weight management in an aging population; and 3) to determine if protein enhances rehabilitation from age-related injury and immobility<sup>[9]</sup>.

## 5. VITAMIN D

Vitamins are organic compounds that allow for energy to be produced, among other functions. They are broadly classified as water- and fat-soluble: water-soluble vitamins dissolve in water and are not stored, but rather eliminated through urine; therefore, a continuous supply is needed in the diet. However, fat-soluble vitamins are not required every day because they are stored in fat tissue and the liver. Fat-soluble vitamins are best absorbed with dietary fat.

Vitamins functions are: production of energy from macronutrients (CHO, fats, and proteins), repair and growth of tissue, maintenance and support of reproductive function, development of immune response. Vitamins are part of so called “micronutrients”.

Vitamin D (25-hydroxyvitamin D (25(OH)D)) is a fat-soluble vitamin. Vitamin D helps the body absorb calcium. Calcium and phosphate are two minerals essential for normal bone formation and maintaining strong bones. Low serum 25-hydroxyvitamin D (25(OH)D) levels have been associated with stress fractures in various physically active populations such as the military. association between low serum 25(OH)D levels and lower extremity stress fractures in military personnel. Given the rigorous training of military personnel, implementing strategies to ensure sufficient 25(OH)D levels may be beneficial for reducing the risk of stress fractures <sup>[10]</sup>, which occur with greater frequency in female war fighters as compared to their male counterparts <sup>[11]</sup>.

## CONCLUSIONS

Protein intake is very important for recovery energy expenditure, to increase MPS and reduce MPB for military personnel during training and in operational theater, especially for SOF. Furthermore, an increased protein intake is beneficial during periods of negative energy balance, in both exercise adaptation and in functional recovery from acute exercise bouts. It has also effects on psychological recovery.

It is important to provide the best quality protein from nutrient-dense protein sources. There are no clear evidences regarding the influence of protein intake on aged warfighters (41-58 years).

An adequate vitamin D intake may be beneficial for reducing the risk of stress fractures in military personnel. A greater attention must to pay in female warfighters, because they are at a greater risk like men.

## REFERENCES

- [1] J Spec Oper Med. 2015 Winter; 15(4):40-53. *Comprehensive Performance Nutrition for Special Operations Forces*. Daigle KA, Logan CM, Kotwal RS.
- [2] J Spec Oper Med. 2014 Fall; 14(3):80-9. *The 10 commandments of nutrition: 2014*. Deuster PA, Lindsey AT, Butler FK Jr.
- [3] Nutrients. 2014 May 12; 6(5):1945-55. doi: 10.3390/nu6051945. *Energy requirements of US Army Special Operation Forces during military training*. Margolis LM<sup>1</sup>, Crombie AP<sup>2</sup>, McClung HL<sup>3</sup>, McGraw SM<sup>4</sup>, Rood JC<sup>5</sup>, Montain SJ<sup>4</sup>, Young AJ<sup>6</sup>
- [4] J Nutr. 2013 Nov;143(11):1848S-1851S. doi: 10.3945/jn.113.175984. Epub 2013 Sep 11. *Is there an optimal time for warfighters to supplement with protein?* Atherton PJ<sup>1</sup>
- [5] J Nutr. 2013 Nov;143(11):1834S-1837S. doi: 10.3945/jn.113.176958. Epub 2013 Sep 11. *Training table to the battlefield: protein recommendations for warfighters*. Rodriguez NR<sup>1</sup>.
- [6] J Nutr. 2013 Nov;143(11):1852S-1856S. doi: 10.3945/jn.113.176057. Epub 2013 Sep 11. *Increased protein intake in military special operations*. Ferrando AA<sup>1</sup>.
- [7] J Nutr. 2013 Nov;143(11):1838S-1842S. doi: 10.3945/jn.113.176545. Epub 2013 Sep 11. *Considerations for protein supplementation in warfighters*. Phillips SM<sup>1</sup>
- [8] J Nutr. 2013 Nov;143(11):1815S-1819S. doi: 10.3945/jn.113.175968. Epub 2013 Sep 11. *Protein supplementation in U.S. military personnel*. Pasiakos SM<sup>1</sup>, Montain SJ, Young AJ.
- [9] J Nutr. 2013 Nov;143(11):1811S-1814S. doi: 10.3945/jn.113.176859. Epub 2013 Sep 11. *Efficacy and safety of protein supplements for U.S. Armed Forces personnel: consensus statement*. Pasiakos SM<sup>1</sup>, Austin KG, Lieberman HR, Askew EW.
- [10] Am J Sports Med. 2015 Aug;43(8):2064-72. doi: 10.1177/0363546514555971. Epub 2014 Nov 4. *Serum 25-Hydroxyvitamin D Levels and Stress Fractures in Military Personnel: A Systematic Review and Meta-analysis*. Dao D<sup>1</sup>, Sodhi S<sup>1</sup>, Tabasinejad R<sup>2</sup>, Peterson D<sup>3</sup>, Ayeni OR<sup>3</sup>, Bhandari M<sup>4</sup>, Farrokhyar F<sup>5</sup>
- [11] Mil Med. 2016 Jan;181(1 Suppl):86-91. doi: 10.7205/MILMED-D-15-00202. *Optimizing Performance, Health, and Well-being: Nutritional Factors*. McClung JP<sup>1</sup>, Gaffney-Stomberg E<sup>2</sup>.

## STUDY REGARDING RADAR CROSS SECTION OF UNMANNED AIRCRAFT

**Larisa POPA**

Military Technical Academy, Bucharest, Romania

**Abstract:** *The radar cross section of an object exposed to a radar is a fictitious area that describes the intensity of the wave reflected back to the radar. Whether expressed as an area or some other quantity, the RCS of a test object is of great importance to a great many individuals in both academia and the defence community. In this presentation I choose to present radar cross section of the UAV because those have an important role in modern war, because we don't need pilot, they have a lower cost and they are more easily engaged in combat. Radar cross section for simple shapes are reviewed with special attention because we have formulas for those, and then can be extended to complex shapes. So I realized graphics for sphere, cone and plane surface with maximum size in all cases 3cm, for frequency of 1GHz, to analyze the result. I realized the model in CATIA for Scan Eagle and Raven, (UAV that we have in Romanian Army) and I imported them in Matlab where I realized charts for radar cross section using the POFACETS application. Finally I analyzed the importance of reducing the radar cross section in modern war.*

**Keywords:** *radar cross section, reflection, UAS, wave.*

### 1. INTRODUCTION

When British scientists started work on radar in 1935, they realized the importance of target reflectivity. If the new method of aircraft detection known as Radio Location was to work effectively, it was essential that the reflection be as strong as possible. When an electromagnetic wave meets an electrical conductor, such as a wire, it creates within that conductor electrical and magnetic currents at the same frequency. The process works both ways - a current in a conductor can create an electromagnetic wave, and an electromagnetic wave can create a current in a conductor. This is the central principle of the phenomenon which causes an aircraft or any other target to reflect radio energy. When the radar wave hits the target, it induces electric and magnetic currents within that object. By the act of flowing, these currents in turn cause an electromagnetic wave to be created. It is this latter wave which the radar sees as a reflected echo.

During the war, engineers in Britain and Germany found that further increases in operating frequency had little effect on target detectability. Since increased frequency allowed a narrower beam to be obtained from a given size of antenna.

## 2. UAV's IMPORTANCE

To define the radar cross section of a target the radar engineer calculates the size of a sphere which would reflect the same amount of radar energy as the aircraft he has measured. The RCS in square metres is than the area of a circle of the same diameter as this imaginary sphere.

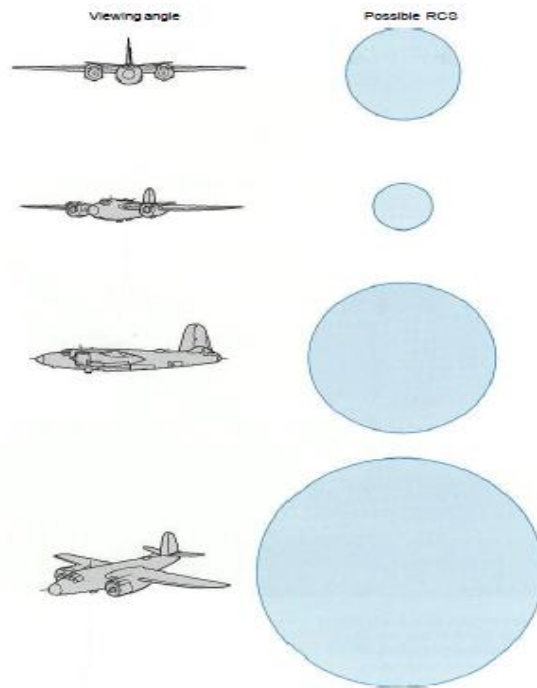

**FIG.1** Variation in RCS with Angle

The acronym UAS refers to the system as a whole (unmanned aircraft-UA) and all direct support equipment. Direct support equipment includes the ground control station, ground data terminal, launch and recovery system, transport and logistics vehicles, operators and maintainers, unit leadership, and others. The acronym UA refers to the unmanned aircraft exclusively and does not include the payload unless stated otherwise. UAS operations support battlefield commanders and their staffs as they plan, coordinate, and execute operations. UAS increase the situational awareness (SA) of commanders through intelligence, surveillance, and reconnaissance (ISR). Armed UAS provide commanders direct fire capabilities to prosecute the close fight and influence shaping of the battlefield. Any UAS can perform some of all of the following functions: enhanced targeting through acquisition, detection, designation, suppression and destruction of enemy targets, and battle damage assessment (BDA). Other UAS mission support the maneuver commander by contributing to the effective tactical operations of smaller units.

The UAS has the great advantage that he has a small RCS and that is unmanned so we don't have a pilot in a dangerous attack mission.

### 3. RADAR CROSS SECTION FOR SIMPLE SHAPES

Radar cross section is a function for many factors which include the target configuration and its material composition, frequency or wavelength, transmitter and receiver polarization, and the target aspect (angular orientation of the target) relative to the radar. The scattering characteristics of a target are dependent on the frequency of the incident wave. Three regimes distinctly differentiate the RCS scattering of a target depending on the ratio of the wavelength  $\lambda$  to the body size  $L$ .

- Rayleigh region ( $\lambda \gg L$ )
- Mie region ( $\lambda = L$ )
- Optical region ( $\lambda \ll L$ )

To determine the RCS of a target of a model I used the pofacets program, a Matlab application. Because every target is built from basic shapes first I've calculated the RCS for different shapes at different frequencies to show the importance of the shape, and I've chosen basic forms that we can find in the shape of UAV and I have determined the RCS in monostatic and bistatic mode. We have the results of different shapes with the same maximum dimension at frequency 1 GHz for: a sphere, cone and a plane surface.

Radar cross section methods for simple shapes are reviewed with special attention being devoted to results rather than to derivations of the formulas involved. In addition, special emphasis is placed on an approach which can be extended to "complex" shapes. Where possible, comparisons between theory and experiment are provided to give a measure of the accuracy obtainable via the use of these techniques. The discussion is limited to perfectly conducting bodies: in particular spheres, ellipsoids, thin wires and flat plates. An attempt is made to cover the complete spectrum of body dimension to wavelength ratios: Rayleigh region, the resonance region and the optics region are all considered from the points of view of both monostatic and bistatic phenomena.

### 4. SIMULATIONS FOR SIMPLE SHAPES

**Cone simulations, frequency=1 GHz, maximum size=3cm**

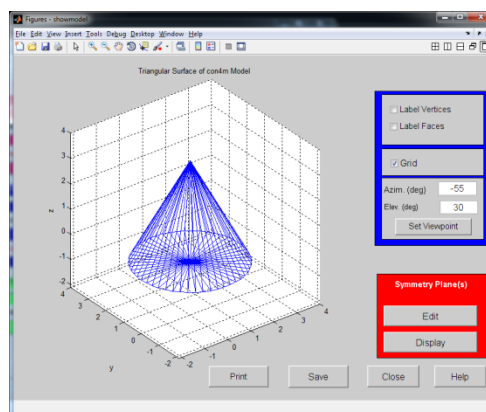

**FIG. 2** Cone in POFACETS

## Monostatic regime

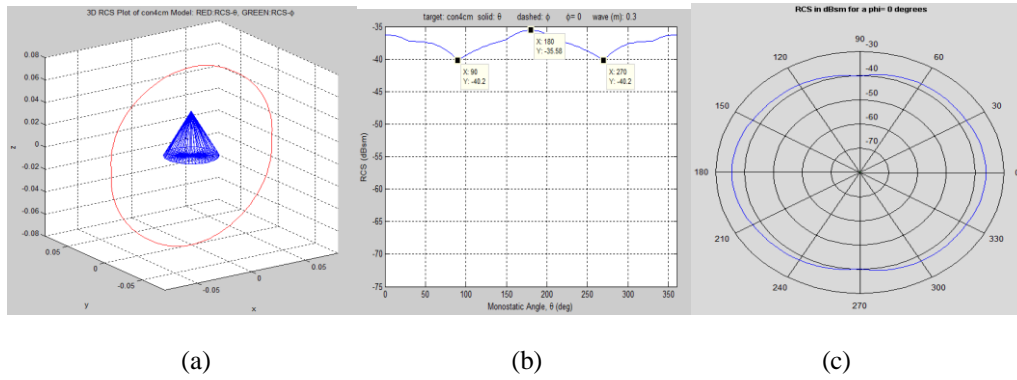

FIG. 3 Monostatic results

## Bistatic regime

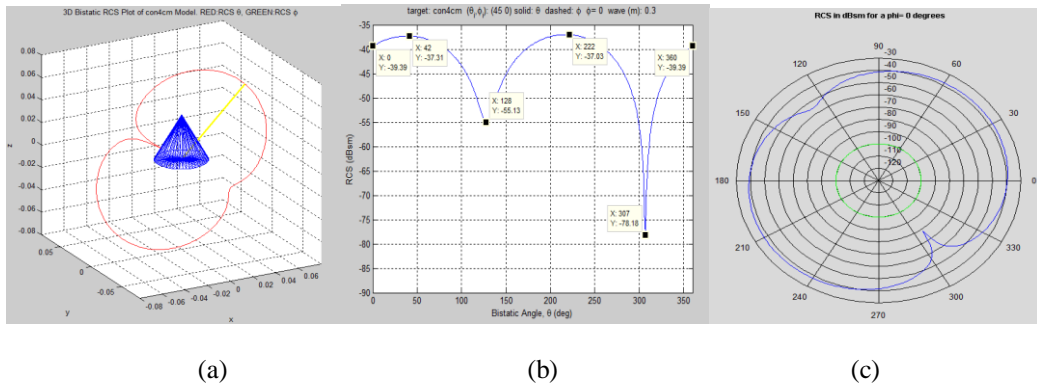

FIG. 4. Bistatic results

## Sphere simulations, frequency=1 GHz, maximum size=3cm

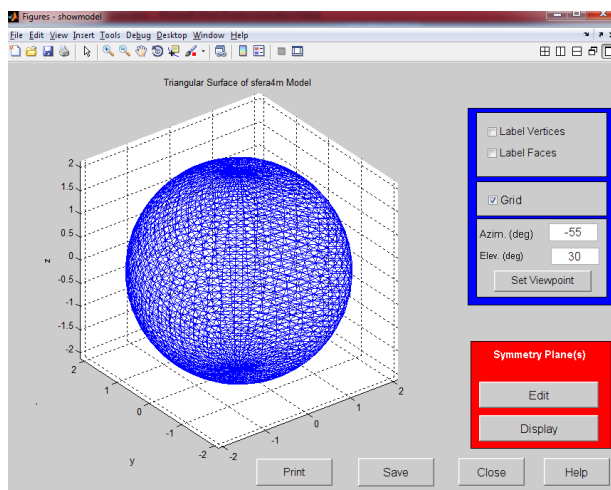
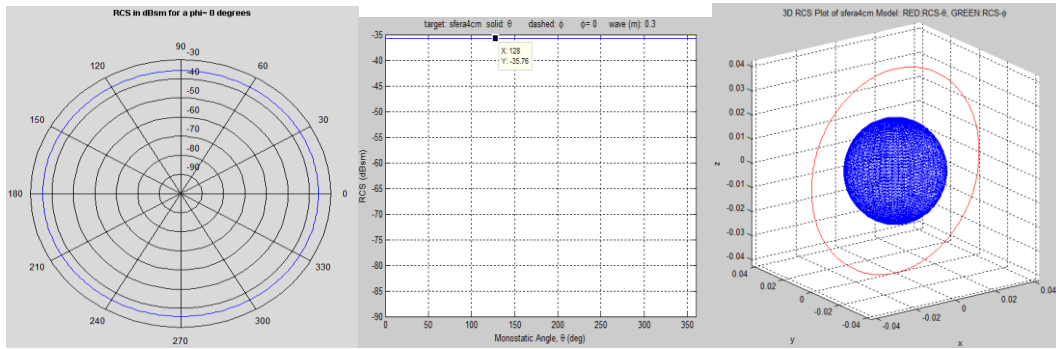

FIG 5. Sphere in POFACTS



**Monostatic regime**



(a) (b) (c)

**FIG. 6. Monostatic results**

**Bistatic regime**

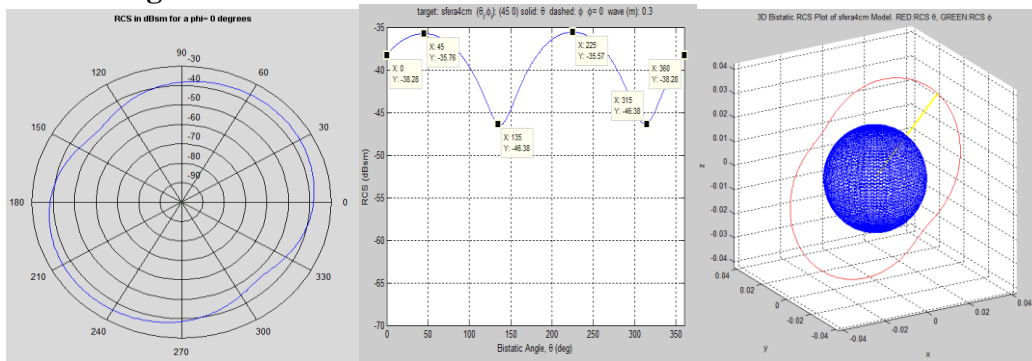

(a) (b) (c)

**FIG 7. Bistatic results**

**Plane surface**

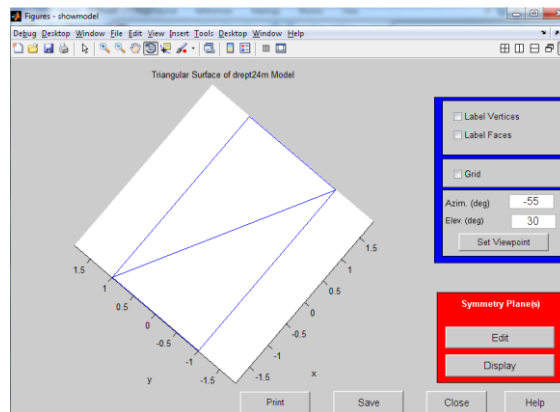

**FIG. 8 Plane surface in POFACTS**

## Monostatic regime

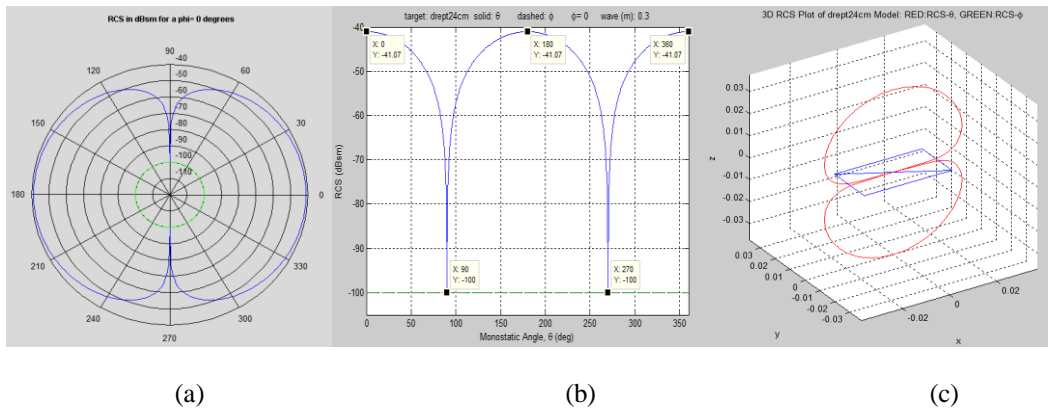

FIG. 9 Monostatic results

## Bistatic regime

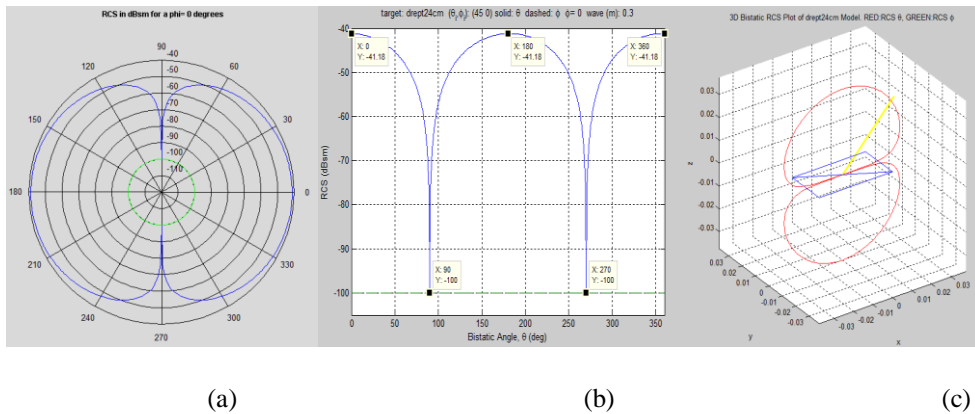

FIG. 10 Bistatic results

## 5. SCAN EAGLE AND RAVEN UAV, REALIZED IN CATIA

To determine the radar cross section, I realized the models in CATIA.

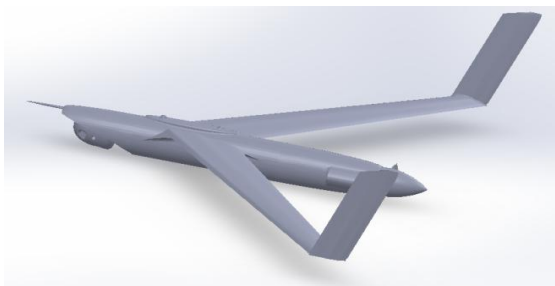

FIG. 11 Scan Eagle in CATIA



FIG. 12 Raven in CATIA

And then I imported them in Matlab to determine the RCS.

## 6. SCAN EAGLE AND REVEN IMPORTED FROM CATIA IN MATLAB

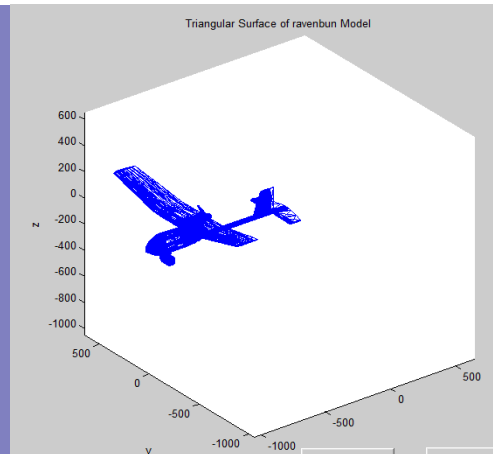
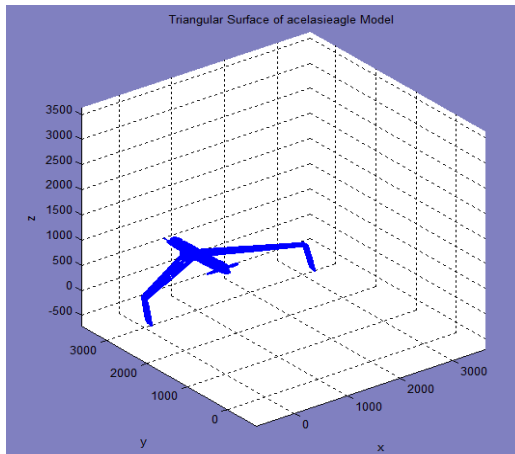

FIG. 13 Scan Eagle imported from CATIA      FIG. 14 Raven imported from CATIA

## 7. RCS REDUCTION

Reduced signature design improves platforms' overall survivability through the improved effectiveness of its radar counter-measures.

Several methods exist. The distance at which a target can be detected for a given radar configuration varies with the fourth root of its RCS.<sup>[11]</sup> Therefore, in order to cut the detection distance to one tenth, the RCS should be reduced by a factor of 10,000. Whilst this degree of improvement is challenging, it is often possible when influencing platforms during the concept/design stage and using experts and advanced computer code simulations to implement the control options described below.

RCS reduction can be realized with radar absorbant material

Radar absorbent material (RAM) can be used in the original construction, or as an addition to highly reflective surfaces. There are at least three types of RAM: resonant, non-resonant magnetic and non-resonant large volume.

## 8. CONCLUSION

Generally UAV have a small radar cross section, so they can be used in many situation like surveillance, reconnaissance, but the importance of reducing the UAV's radar cross section is useful especially for UAV, which are used to carry chargers fight like bombs and missiles. Their importance is growing because besides advantages related to a small radar cross section(so they can't be detected by the radar), they don't need a pilot.

RCS reduction is chiefly important in stealth technology for aircraft, missiles, ships, and UAV. With smaller RCS, vehicles can better evade radar detection, whether it be from land-based installations, guided weapons or other vehicles. Reduced signature design also improves platforms' overall survivability through the improved effectiveness of its radar counter-measures.

## REFERENCES

- [1] Adamy D., *EW 101: a first course in electronic warfare*, Artech House Inc., Norwood, 2001
- [2] Baran A.K., *Technology in Warfare: The Electronic Dimension*, Emirates Center for Strategic Studies, 2009
- [3] Bălan C., Popescu E., *Principii și mijloace de ducere a războiului electronic*, Editura ATM, București, 1998
- [4] Boyd J.A., Harris D.B., King D.D., *Electronic countermeasures*, Peninsula Publishing, Los Altos, CA, 1978
- [5] Grant R., *The Radar Game: understanding stealth and aircraft survivability*, IRIS Independent Research, Arlington, Virginia, 1998
- [6] Richardson D., *Stealth Warplanes*, MBI Publishing Company, 2001

## HUMAN-MACHINE INTERACTION

**Gabriel-Dorian GLĂMAN**

"Henri Coanda" Air Force Academy, Brasov, Romania (glamangabriel@yahoo.ro)

***Abstract:** This article provides a general perspective referring to the characteristics of the components of aircrafts. The first part provides a short introduction relating to the complexity of modern aircrafts. The second part focuses upon the Hardware component of the electronic part in modern aviation. The third part includes characteristics of the Software part as an integration system for the pilots as users. The last part deals with the basic automation that assists the pilot and provides information about the environment and the aircraft.*

**Keywords:** hardware, software, hardware and automation, digital, design, controls.

### 1. INTRODUCTION

Man has adapted the environment to match human requirements in the air through system such as pressurization, soundproofing and air conditioning to control temperature and humidity.

The two interfaces to be considered are those of Hardware and Software. Between those two components of the electronic part of aircrafts must be a correlation in the way of modernization and of course for helping the pilots to control the aircraft by providing more and more information and in specific cases the electronic part take the control of the aircraft in an automatic way. The following article shows the basic hardware and software components that are included in the modern aircrafts.

### 2. HARDWARE

Hardware has specific components for aircrafts as are shown below:

- a) Design of Flight Decks ;
  - Eye datum

Eye datum describes a basic feature of a cockpit design. The pilot should be able to view all important displays within the aircraft and maintain an adequate view of the world outside without the need to make more than the minimum of head movements. It follows that the cockpit space must be designed around a defined position of the pilot's eye. This position is named also Eye Datum, Design Eye Position or Reference Eye Point and is often indicated in the cockpit by the provision of an indicator on the central windscreen pillar which only appears aligned when the pilot's eye is at the designed point.

If the pilot should be sitting below the eye datum then the undershoot will be obscured, if sitting higher than the datum, the overshoot are may not be visible.



**FIG. 1.** Eye Datum

- Aircraft Windows

External vision is of great importance but the size and shapes of windows will be determined by aerodynamic and weight restrictions. Large window will need to be of thicker glass and require stronger and thicker frames, a compromise must be reached whereby reasonable external vision is obtained without too great a weight penalty.

- b) Displays ;

- Presentation Requirements

When deciding on the best way to display information we have the basic choice of a digital or analogue display. Even when using a cathode ray tube to show information we have the choice of a digital or an analogue display. Experiments have shown that for the display of purely quantitative information then digital displays give the better results. For displaying qualitative or comparison information then an analogue display provides more easily assessed information.

- Standardization

This should allow the pilot to make an easy transfer from one aircraft to another with minimum training time and expense. Standardization can also prevent accidents due to the transfer of procedures between aircraft types and models. Total standardization is not possible and would inhibit new design technology, but it should certainly be the goal for all similar types within an operating fleet.

- Conventional Analogue Standard “T” Display

An aircraft using conventional display will usually have a standard “T” lay out in which the most important instrument, the artificial horizon or attitude indicator is at the center. The other primary flight instruments, altimeter, airspeed and direction indicator, are grouped around it.



FIG. 2. Standard "T" Display

- Digital Display and the Compass

The conventional compass card gives a better picture of the aircraft orientation. A digital readout for heading makes it more difficult to determine such factors as the shortest way to turn onto a new heading however it is ideal for the display of quantitative information.

- Combination of Analogue and Digital Displays

It is practicable to combine both digital information and analogue information in a single instrument in which the thousands and hundreds of feet are displayed digitally. The hundreds of feet are also shown by a single pointer. The use of a single moving pointer against a fixed scale will give a much better mental picture to the pilot when approaching the end of the scale. This form of display is also excellent for showing small changes such as when levelling off or departing inadvertently from the selected altitude.

- Glass Cockpit Display

Basic presentation is maintained to some extent in the modern "glass cockpit", in which the instruments are displayed on a Cathode Ray Tube (C.R.T.). The attitude may be presented in the traditional way but other items, such as speed and altitude, may be displayed on moving tape display, with a conventional compass card, or as a digital display readout.

- Tapes and Perception of Rolling

The use of tapes does present some problems in the climb and descent. It we maintain the convention of having the high figures as the top of the presentation then during a climb, with a decreasing speed and an increasing altitude, there may be a perception of the aircraft rolling.

Other displays have the higher values at the bottom of the displays. As there is no industrywide standard for presentations of information it is possible, on transfer of aircraft type, to have presentations working in opposite senses to which the pilot has become familiar. Such a state of affairs is plainly undesirable and a recipe for possible errors.

- Head Up Display

A promising development for future displays is the Head Up Display (H.U.D.). In this system the information required by the pilot is projected at infinity it enables the pilot to view the outside world through the display. It has been in use for many years in military aircraft and is now being incorporated into commercial aircraft.

The greatest success is in the presentation of ILS information on the windscreen, when information from the ILS equipment is processed by a computer to show a constantly changing picture of runway data as the procedure is flown. Although there is no requirement for a change of eye focus for the pilot, there is still the need for the transfer of attention.



FIG. 3. Head Up Display

- Voice Presentation

An alternative method of presenting information is the use of a recorder voice message. This technique has been developed in some experimental aircraft but has not been adopted for normal commercial aircraft. The voice has been found distracting and after a time tends to be ignored. Voice information has only found a major use in the Ground Proximity Warning System (G.P.W.S.) and Traffic Collision Avoidance System (T.C.A.S.) systems.

- c) Engine Instruments

- General

As the information from the engine instruments is as relevant to the pilot as that from the flight instruments, it is important to ensure that these instruments are not only easy to read but as far as possible unambiguous. The instruments in each column should all relate to only one engine, and the instruments in each row should show the same information (RPM, TIT, torque).

This enables the operator to spot immediately any discrepancy on any instrument and identify the engine concerned in the minimum time. In an ideal layout the columns of instruments will be aligned with the appropriate power lever, all No 1 engine instruments being above No 1 power lever and so on. Another aid to rapid identification of a problem is to rotate the instruments so that all needles are aligned, vertically or horizontally, in normal cruise flight.

- Primary and Secondary Instruments



As well as the primary engine instrument a number of instruments are required to display secondary information. There are a number of different possible configurations.

There are advantages and disadvantages to each layout. The ideal layout could have a bank of instruments below the primary instruments but cockpit space may not allow this. As the purpose of these instruments is to warn the pilot to the correct identification of the engine concerned, there is a great deal of research needed to identify the best layout for each aircraft type.

- Cockpit Lighting

All instruments need a lighting system to enable readings to be noted in all light conditions. On conventional dials there is a choice of internal lighting on each instrument or external light to illuminate a group. In most cockpits there is a mixture of both internal and external lights. In the glass cockpit display the brilliance control will act as an adjusting mechanism to cater for varying light conditions. Once set, the screen brilliance may be automatically retained by an ambient light sensor fitted in the cockpit.

What is essential is an adjustment system that allows for both the state of natural light and individual preference. All lighting system should avoid harsh shadows and reflected glare.

There has been a tendency in modern civil flying to use higher brightness levels on the flight deck. Research has indicated that on long night flights, fatigue and drowsiness seem to be less with higher brightness levels. With age visual acuity decreases, and older pilots require a higher brightness level.

Should there be a possibility of thunderstorms or lightning, cockpit lights should be turned fully up to reduce, as far as possible, the “blinding” effect of flashes.

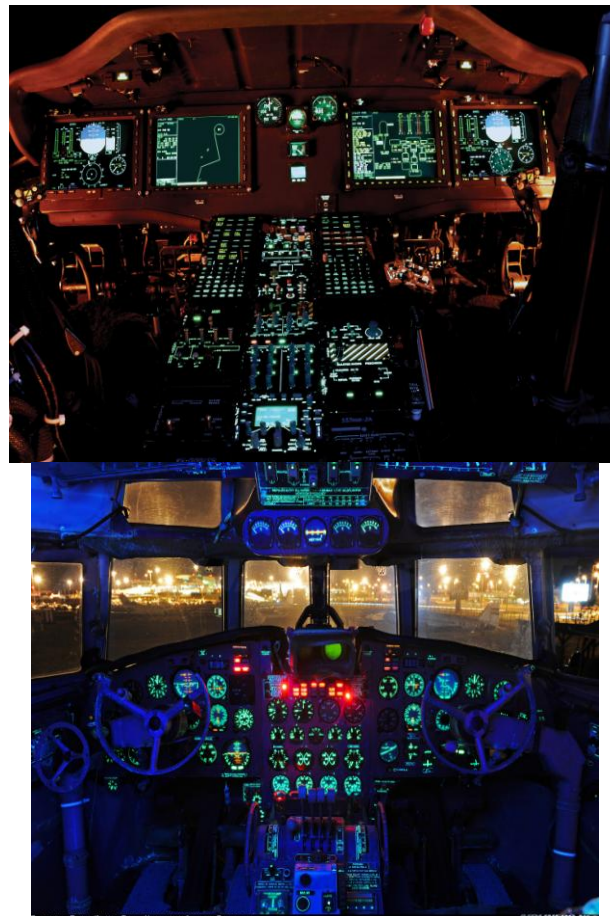

**FIG. 4.** Different lighting in cockpit

#### d) Controls

- Basic Considerations

Display enable information to be passed from the aircraft to the pilot – controls enable instructions to be passed from the pilot to the aircraft. There are certain basic considerations which govern the way controls should be designed and arranged.

- Standardization

Most importantly, controls should be standardized in their location and sense of use from one aircraft to another, and between different aircraft types. For example, to operate a manual valve, rotation should be:

- Clockwise to close
- Anti-clockwise to open

- Frequency of use

Controls should be located such that they are within an easy reach envelope of all designed users of the aircraft. Controls that are used frequently or for protracted periods should be located so that they do not require an awkward or fatiguing posture of the pilot.

- Sequence of use

Controls that are frequently used in a given order should be laid out so that the sequence of use is represented in the layout of the controls. As well as convenience, the layout itself acts as a prompt for the pilot.

- Importance

Important controls must be located in easily reached and unobstructed positions.

- Visual/Tactile dissimilarity

Switches and knobs that control different functions should not look or feel the same thus reducing the chance of inadvertent operation.

- Symbolism

Controls, if possible, should be designed to contain some reference to their function. Thus undercarriage levers can be shaped like wheel and flap levers can resemble a cross section of a flap.

- Control/Display compatibility

Controls should be located such that they maintain some spatial logic with the display that they are associated with. For example the columns of engine instruments should be aligned with their relevant power levers.

- Control loading

The force required to operate any control should not only be within that which can be exerted by the target population of pilots but should be harmonized with the forces required by order related controls. For example, a control column will be difficult to use if it requires a large force to control roll but only light force to control pitch.

- Prevention of inadvertent use

Controls should be designed to minimize the chances of inadvertent operation. Where this could be dangerous, the control should be fitted with a guard.

- Control position and present demand

The position of the control should indicate the selected function. In some modern cockpits the conventional column has been replaced by a sidestick. Both pilots' sidestick should move in unison so that, on change of operator of pilot taking control will know the already selected position.

- Simultaneous use

Those controls requiring simultaneous use, such as the throttle and trim controls, should be located to enable this to take place.

Great progress is being made to meet all the above requirements but even today there are problems with some aircraft designs. Some are merely a nuisance but others should not be tolerated.

- Warnings

It is essential that all warnings should be “attention getting” without being startling. As well as attracting attention the warning should inform the pilot of what is wrong and if possible guide the pilot to the correct actions. The alerting function for all important failures should be fulfilled by an audio warning. This is mandatory if the pilot is required to assume control.

Even the most conspicuous visual warning rely on head and gaze orientation. In a more extreme example, the use of any visual warning is rendered useless if the pilots should be asleep. The ideal warning system is to have a single audio warning to alert the pilot to a failure and to direct his attention to a single central warning panel that announces the nature of the problem with suitable illuminated caption.

It is vital that warning system be reliable, that is they respond to all genuine problems, but do not generate false alarm. Early GPWS systems were well known for generating spurious warnings and it has been suggested that CFIT accidents have been caused by pilots ignoring genuine alarms.

## **2. SOFTWARE**

Software part of the aircraft involves more accurate principals to generate a perfect design for the pilot.

### a) Checklists and Manuals

The importance of good design in checklists is fundamental to the safe operation of aircraft. Aircrew must be afforded rapid accessibility to accurate information in manuals and checklists. There is plainly a requirement for crew to be sufficiently familiar with their documentation so that they know where to find relevant information in the quickest possible time.

### b) Use of color

Color is a preferable way of categorizing information and giving importance to different sections of text, but the legibility of different text/background may well vary under varying light conditions.

### c) Checklist – Design Usage

The maximum benefit is obtained from checklists when the pilot adheres to the designed procedure. If the checklist calls for a challenge and response, then this is the way it should be used.

## **3. HARDWARE AND AUTOMATION**

Since about 70% of all accidents in aviation are attributed to human error it is understandable that companies are looking for ways and means to eliminate the human element as far as it is safety possible. Thus automation is on the march and is a fact of life. However, with it comes a number of new problems.

Automation is to assist rather than replace the pilot, leaving him/her to make higher level decisions. The pilot must at all times remain in control of the automation and be aware of what it is doing.

Automation in aviation is a system or part of a system, which when activated, effects a predetermined sequence of actions autonomously in a limited period of time. Under normal conditions, the pilot has no control over it and cannot deactivate it. Generally automation is embedded in the execution chain of a system. Protection Automation is an automatic action which is triggered as a safety limit is passed. It cannot be disengaged by the pilot. Support System is system displaying processed or diagnostic information that can be instantly used by the pilot. Glass Cockpit is a cockpit design characterized by computer-generated visual display the minimum of which is a Primary Flight Display and a Navigation Display. The term is sometimes incorrectly used when referring to an aircraft equipped with screens reproducing standard instruments.

## **CONCLUSIONS**

Computers do those things that pilots already know how to do well, much better than pilots. But computers do not know how to do those things that a pilot would like to do well. In essence, the irony is that pilots are to oversee an automated system, which they do poorly, and take over when there are abnormal conditions, which they may not be very good at either.

Aircraft automation is gaining ground and is here to stay. It is a tool and, as we have seen, it is far from a panacea. Certainly it has gone a long way to solving many of the traditional problems but, in its wake, brings those of its own. As any tool, its effectiveness depends on the user. It should be handled in the correct way and with an awareness of its weaknesses and dangers. Used badly it can lead to catastrophic results but handled well it becomes a major contributor to flight safety.

## **REFERENCES**

- [1] [http://www.skybrary.aero/index.php/Human\\_Machine\\_Interface\\_\(HMI\)](http://www.skybrary.aero/index.php/Human_Machine_Interface_(HMI))
- [2] [http://www.skybrary.aero/index.php/Cockpit\\_Automation\\_-\\_Advantages\\_and\\_Safety\\_Challenges](http://www.skybrary.aero/index.php/Cockpit_Automation_-_Advantages_and_Safety_Challenges)
- [3] [http://cdn.intechopen.com/pdfs/37990/intech-automation\\_in\\_aviation.pdf](http://cdn.intechopen.com/pdfs/37990/intech-automation_in_aviation.pdf)
- [4] <http://www.airforce-technology.com/contractors/electronic/ayesas1/>
- [5] <http://aviation.siu.edu/technologies>

## IMAGE OF A SOLDIERS PRESENTED BY MASS MEDIA COMPANIES AS A POSSIBLE THREAT FOR THE NATIONAL AND INTERNATIONAL SECURITY

**Selda AHMEDOVA**

”Vasil Levski” National Military University, Faculty of Aviation, Bulgaria  
(s.nedimova@gmail.com)

***Abstract:** Nowadays, every single human-being of a society faces problems connected with a popular culture. Starting with a children from the kindergarten, through teachers and doctors finishing with the politicians as well as soldiers. In my personal opinion, there is no exception. Everyone is equally susceptible with a mass media creations. But why it is so important in case of soldiers ? Why it can be dangerous for a domestic and international safety ? Well, I will do my best to provide you with a full and complete answers for those questions.*

***Keywords :** Mass media, image of a soldier, international and national safety, pop-culture society.*

### 1. INTRODUCTION

Impact of mass media on a present society is rapidly growing and seems to be unstoppable. As everything in the world society is divided in groups which I would rather like to connect with a job or professions than nationality or skin-color. Image of a ‘stars’ created by mass media corporations is developing as fast as the needs of society are changing itself and is different for every single part of the human-being race. Young teenage girls want to be beautiful as a princesses from Disney’s cartoons and wise as Hermione from ‘Harry Potter’ movie, boys as brave as superheroes from the Marvel’s stories and muscular as legendary Heracles. Once achieved a tiring and not easy goal – they want to share their results with friends, family and rest of the society. What is pretty obvious, because they worked hard and now need a reward, in this case – to become famous. The same thing happens in case of soldiers. Usually, it is really hard way to become a defender of a homeland.

Years of studying and sacrifices, long trainings far from home and adjusting to the special type of life style can be seen as something really demanding. And It is indeed. That is why mostly young (but it is not a rule) soldiers want to share their results with modern society – and the social media like Facebook or Instagram, gives them an amazing opportunity, to gather glory with pressing just one button. Once started race of fame, never ends.

## 2. COMPUTER GAMES SOCIETY

According to the common used definition, mass media are divided into five general groups, starting with Internet, through television and radio up to the magazines as well as newspapers. Speaking behalf of the generation that grew up with an easy access to computer, one very important part is missing in the definition mentioned before. These are computer games itself. Regarding to the recent researches provided by American Gaming Corporation, games connected with military are the most popular around the whole world. Main character that u are going to be in a game, is created as a perfect, well equipped and almost immortal hero winning the big battles, conquering enemy's territory and saving the world from the immediate extinction. But the graphic creation it just a part of the manipulation. Second part is the name of the game that provides the player with a fake feeling to be important and irreplaceable, like 'Medal of honor', 'Call of Duty' or 'Company of Heroes'.



However, all the sources of mass media like newspapers or television have an impact on random people, computer games are the exception. They are pointed for a specific part of society interested in military, which makes them even easier to be manipulated.

## 3. INFLUENCE OF THE TELEVISION

Image of a soldiers is easily distinguishable in TV movies as well as TV series. The first example that I am going to provide you with, is the polish TV-series called 'Time of honor'. Action is undertaken in Warsaw during second World War. Ten underground officers of Polish Army are fighting with a Nazis for freedom of Poland.

As well as they accomplished many dangerous missions there was a time for them to have a normal life, fall in love and start up a family. However they were poorly equipped and over numbered, none of the died during first three seasons of a series.

Another crazy good example of a movie manipulation with an image of a soldier is a well-known American production named 'Top Gun'. Young and handsome jet fighter pilot 'Maverick' (Tom Cruise) faces a problems connected to the cold war with Russia. He wins multiple air battles and 'swim in a glory' of a hero, obviously surrounded with a girls.

If It comes to the image of a soldier- pilot, I feel obligated to mention about a 'Pearl Harbor' movie, where two pilots being in love with the same woman, fight to death with a Japanese Kamikaze. Influence of the Television medium, is quite similar to computer

games regarding to the name of the productions, but is very different in comparison of a targets.

Movies put an impact at almost everyone. Field of interests, gender, age or job is not really important. Except of the story about a soldiers there is always side story about love or pain, or love that provides a pain.

#### **4. REASONS TO BECOME A SOLDIER**

To give you a prove that my thesis are not wrong, I have made a questionnaire among my friends from the army of Poland, Hungary, Great Britain and Romania. The question was 'Why have u decided to become a soldier/pilot'. I asked 100 cadets and professional soldiers and the results are as follows. 20% of them, answered that they made a choice to be a soldier because of the passion, interests and life stability, 23% showed their family traditions as a main reason, 17% answered that for them it's a kind of a patriotic obligation to defend a homeland. What happened with the rest of the votes? 35% people asked, answered in a way I understand to be under impact of mass media manipulation like: status in the society, attraction of girls or just simple fun connected with a job itself.



#### **5. FACEBOOK AS A POSSIBLE SOURCE OF THREAT**

Modern society is equipped in probably the most dangerous weapon ever created by human – social media. In this case, I mean Facebook. Almost every single soldier, military unit or army committee has a Facebook fan-page to gather followers, fame and glory.

Starting with a cadets of military academies, professional soldiers, politicians connected to military, finishing with a NATO commanders and generals. Sharing photos among the social media provide others with a full details about time, location, people on the photo (with full name and surname) as well as short description of the happening. It is probably the easiest way for foreign intelligence services and terrorists to find and track their targets. However killing a single human by a random psychopath has no impact for the other people, killing a general, commanding officer or even single soldier is a way to weaken the whole defense system of a country, what can be a serious problem and danger for a nation.

#### **6. CONCLUSIONS**

Definitely the level of security conditions in the army or international organizations like NATO must be improved to prevent terrorist attacks in the future.

Intelligence services of every single country should rise the undertaken steps to make finding information about soldiers as hard as it is possible. In my personal opinion the image of the soldier must be classified. However uploading a photos of a soldiers is already forbidden –this rule is not followed by masses. As I said at the beginning, rules of social life are equal for everybody.

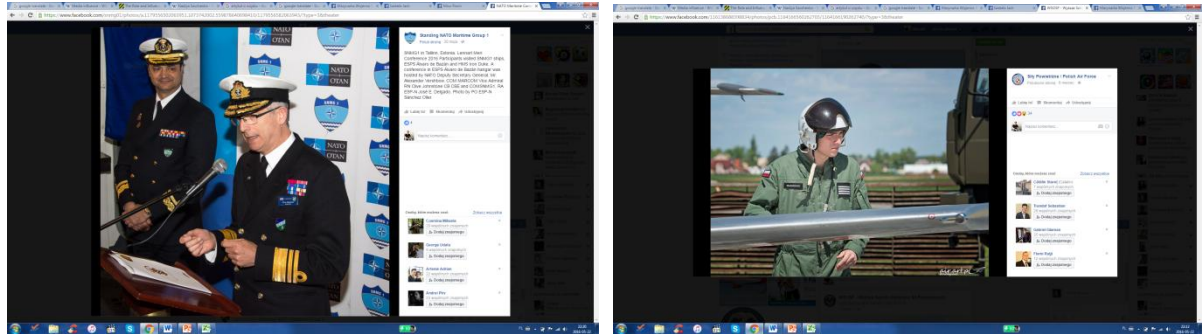

It does not matter if you are a baker, teacher or a soldier. Run of fame is obvious and understandable. No one want to be pushed aside of a society, that is why I think soldiers who break the rule should not be punished. We just have to find a way to erase not wanted photos as fast as possible, or create a new way for soldiers to gather glory and fame.

## REFERENCES

- [1] Kozłowska Anna, *Oddziaływanie mass mediów*, Szkoła główna handlowa, Warszawa 2006;
- [2] Wimmer Roger and Dominick Joseph, *Mass media. Metody badań*, Wyd. UJ, Kraków 2008;
- [3] Scott Tony, *Top Gun*, USA, 1986;
- [4] Bay Michael, *Pearl Harbor*, USA, 2001;
- [5] Hanks Tom, Spielberg Steven, *Band of Brothers*, USA, 2001;
- [6] Wencel Ewa, Sokół Jarosław, *Czas honoru*, Polska, 2008-2014.



## AVIATION AND NOISE

Aleksandra ŚLIWIŃSKA\*, Andrzej ŚLIWIŃSKI\*\*

\*War Studies University, Warsaw (alesliw@gmail.com)

\*\*Gdynia Maritime University (sliwinskiandrzej@hotmail.com)

**Abstract:** Aviation is relatively new kind of transportation. At the beginning of that business - in the interwar period, it was not designed to carry people. At the end of World War II, there were recognized the potential of aircrafts and planes to use them to carry passengers on a wider scale. From that moment everything began to change- On December 17th, 1944 has been signed the Chicago Convention, which caused establishment of International Civil Aviation Organization - the most important aviation management institution. Since then, the importance of aviation strongly increased. Had begun times, when people started discovering the newer, faster, better constructions of aircrafts. All attempts to create new technologies aimed at providing a longer, safer and more economic trips by air. Mainly the focus was on performance, with a greater coefficient of filling, and making the planes more economical. However, about the problem of environmental friendliness nobody cared too much. During designing and construction's processes of new pieces of aircrafts, the architects did not look at the fact if the machine will be producing and emitting into the atmosphere any harmful substances which could cause some damage and degrade the environment. The biggest impact onto people from all environmental pollution, made by the performance of air transport, has noise. Its influence and impact of its production is immediate and directly can cause the damage. Although it is local phenomena, which influence on the specific group of people, it occurs on the whole Earth. Unfortunately, it is getting more and more serious, despite there are better, newer technologies which are quieter, if we compare them to those which were produced few years ago. What is more air transport is getting more popular mean of transportation among the people, the capability is growing etc. There should be done something to reduce that negative impact. Among others, the solutions are presented in that work.

**Keywords:** aviation, air transport, noise, solutions, environment, sustainability.

### 1. THE NOISE AND ITS INFLUENCE ON THE ENVIRONMENT

The need for peace, which is even noticed as main need in Maslow's hierarchy of needs, it is undoubtedly important to many people who are among the most challenging elements of the environment. Many people would agree with the statement that in place where is no silence, where is continuous and arduous for the organ of hearing environment, is very difficult to concentrate, think, talk and even stay. The sound level, measured and defined in decibels (dB), which the human ear is able to stand without pain, lies within 0-130dB. However, already above the 40dB, sound, in fact noise, because like that is determined not pleasant, unwanted sound coming from the environment and preventing work and leisure, has a negative impact on the human body. This value is very easy to achieve, because even 40dB can produce a simple, quiet conversation between two people. Of course, huge impact of receiving noise by the organ of hearing has a frequency, volume, length and height variation of dB at certain time.

The specific noise produced in specific environment is a problem that affects only a certain group of people, because it is a phenomenon polluting the atmosphere and contributing only to the local area. Nevertheless, it is undoubtedly subjective, and each entity will receive it in a different way, however, it is undesirable that it affects everyone. According to research, noise is one of the key issues which affects and decrease the quality of life in Europe<sup>1</sup>. It is known that above the pain threshold, ie. 130dB can start in the human body vibration of the internal organs, which in turn can lead to illness and even death, so that problem should not be underestimated.

The result, which affects the highest amount of people, and which can appear almost immediately after exposure sense of hearing to noise, is damage or even loss of hearing. A group of people, which is most exposed to such damage caused by the performance of air transport, are those people who are employed at the airport, as well as those who are working with aircrafts, involved in the maintenance and doing their professional duties at the airport. These are people who spend usually 8 hours a day, every working day during the week, in an environment which is directly exposed to "air noise". Although many of them, according to health and safety instructions should wear special headphones, causing mute the sound. Although it still has unhealthy impact and prolonged exposure of that phenomena can cause insomnia, irritability, fatigue or loss of concentration.

As a result of increasing mobility of society, near large cities, are located airports that provide air transport by airplanes, which is getting more and more popular kind of transportation. It happens really often, that the capitals and other major cities, have more than one airport, where a scheduled air services with the regular flights are provided (eg. London has 7 airports, Warsaw and Bucharest- each 2 airports). Along with the rise of numbers of airports, there is getting bigger problem of their impact on the environment. The biggest, perceptible immediately and influencing the environment result, is the sound, produced and coming from the boundaries of the airport to the local areas.

High sound produced by the aircraft is not emitted only during takeoff and / or landing, which, as calculated is in the range 74 and 108 dB (depending on the type and age of the aircraft)<sup>2</sup>. Its creation is also contributed by airplanes which are moving, or staying on the movement area (which include the part of the airport designated for take-off, landing and taxiing of aircraft, the manoeuvring area and aprons)<sup>3</sup>. That noise, does not only stay at the area of the airport, also reaches the areas located even to few kilometres away from the administrative border of the aerodrome. It is not possible to close the sound- it will be always diffused and reached beyond places behind the airport's borders. According to the Figure 1, daily average noise level in these areas, is between 80-100dB. The noise getting to the area near airport, while measuring can be different, for the same type of aircraft and distance, but with different type of background of those areas. According to some researches, difference can be even 10dB (e.g. the sound is lower above the rural areas than in the communities)<sup>4</sup>.

---

<sup>1</sup> *Hałas w środowisku. Zanieczyszczeniem środowiska hałasem* [online]  
<http://www.ekologia.pl/srodowisko/ochrona-srodowiska/halas-jest-zanieczyszczeniem-srodowiska,5252.html>

<sup>2</sup> I. Leśnikowska-Matusiak, A. Wnuk, *Wpływ hałasu komunikacyjnego na stan środowiska akustycznego człowieka*, 2014, p.44 .

<sup>3</sup> Annex number XIV to the Chicago Convention from 17 of December 1944.

<sup>4</sup> C. Lim, J. Kim, J. Hong, S. Lee, *Effect of Background Noise Levels on Community Annoyance from Aircraft Noise*, *Journal of the Acoustical Society of America*, 2008, Vol. 123, p. 766–771.

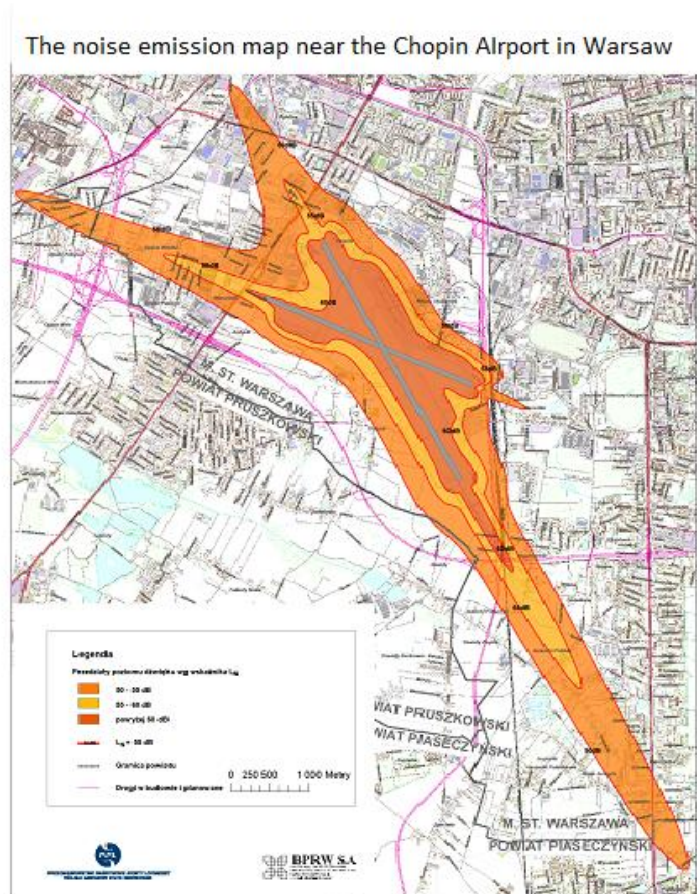

**FIG. 1** The noise emission map near the Chopin Airport in Warsaw

Source: [http://www.lotnisko-chopina.pl/uploads/user\\_files/ochrona\\_srodowiska/mapa\\_akustyczna/2012/mapa-emisyjna-ln.pdf](http://www.lotnisko-chopina.pl/uploads/user_files/ochrona_srodowiska/mapa_akustyczna/2012/mapa-emisyjna-ln.pdf)

The Figure 1 shows how the noise, created at the Frederic Chopin Airport in Warsaw is emitted to the surrounding areas. It is shown that the most probable places with the lack of silence are located on the extension of runways. Starting / approaching to landing aircrafts, which are the main reason of noise during the performance of air transport, fly directly over these ground surfaces. The noise generated by working aircraft's components, as well as air stream sucked in by the compressor, gas flows released from the combustion chambers and excreted into the atmosphere, (usually) except the vertical distance do not have other barriers, which could in any way decrease the sound<sup>5</sup>. Usually noise which is approximately 60dB in the boundaries of runways, reaches areas located over 4.5 kilometres, even in the intensity of 50dB<sup>6</sup>. On that bad impact of noise are exposed people, who live nearby, or are in the area by chance. People working in positions related to the performance of air transport are in kind of way aware that loss of hearing or the ear-problems for them are kind of "occupational hazard". However, the health and safety of the employees is very important, and in any case should not be exposed to situations where they are exposed on damage of their health.

<sup>5</sup> S. Zajjas, D. Ozga, *Lotnictwo a środowisko naturalne*, Warsaw 2011, AON, p.24.

<sup>6</sup> C. Sequeira, *An Assessment of the Health Implications of Aviation Emissions Regulations*, Master of Science Thesis MIT, 2008, p. 31-32.

The worst for people living near airports can be aircraft's flights, which take place at night. During the silence of the night (between 10:00 p.m. and 6:00 am) sounds, such as made by moving cars, trains, noise resulting from industrial activity, etc. are declining, fewer people are moving on routes, schedule of train is much lower etc., so the noise produced during airplanes' operations reaches. The living around airports people, can hear the noise from airports with greater intensity, because it is not drowned out by other sounds produced in the nearby areas. Those residents are exposed to noise and are deprived of the right to peace, rest and silence even during night. Long-term exposure to noise on human health is one of the stressors and may contribute to irritability, stress, states of chronic fatigue, sleep disorders, cardiovascular disease, decrease in concentration in children and adults<sup>7</sup>. Although the frequency of passenger transport traffic decreases at night, it is a very popular part of the day for the flight with a cargo freight on board. Such transportation is more popular- currently carries 40% of international exports of goods<sup>8</sup>. Residents of neighbourhood's areas or towns located near the airport for the noise associated with the operation and use of air transport are exposed mainly for 24 hours a day. It is rare that they can in silence, without noises coming from the airport to rest. That situation does not soon change, because it is estimated that on average, each on four company is relying on air transport<sup>9</sup>. The limitation or prohibition of use of air transport would undermine the industry and economy of each country.

Currently, the technology is developing. There are created newer and above all, quieter aircrafts. People who are using air transport services offered by the airlines, are exposed to less annoying, at first sight, noise during their journey in the air. A few years ago, without a doubt, we can say that air travel was much louder, and it was influencing not only to the passengers but also to cabin crew. The aircraft is theirs place of work, reside inside it their entire working day. Despite the fact that today the aircrafts are quieter than a few years ago, noise is still getting into the passenger compartment (mainly as a result of the working motors). People on board of the aircraft are exposed to the sound intensity, which negatively affects their bodies and health in general.

Noise are not only audible to the human ears sounds, but also infrasound, or sound waves at too low frequency which are not able to pick them up by humans' auditory organ. They are mainly used to communicate by mammals such as elephants and whales. Those sounds can be contributed by natural sources (waterfalls, sea waves, waves, already mentioned animals, etc.), as well as the man-made sources (derricks, vibration bridges, jets, helicopters). "[...] Infrasonic vibrations of the fuselage completely penetrate the pilot's body. This can cause extended response time, visual impairment, incorrect assessment of the situation and drawing illogical conclusions. Therefore, pilots' flight time [...] is limited to the minimum necessary<sup>10</sup>". From this quotation it can be concluded that even what we actually do not hear, can have a significant impact on the human's body and can harm the body. In the case of a pilot that impact even can lead to disaster. What is more, infrasound can also cause confusion and deafening natural animal's communication.

---

<sup>7</sup> I. Leśnikowska-Matusiak, A.Wnuk, *Wpływ hałasu komunikacyjnego na stan środowiska akustycznego człowieka*, 2014, p.43-44.

<sup>8</sup> M. Jeż, *Lotnictwo a zrównoważony rozwój*, Biblioteka Naukowa Instytutu Lotnictwa, Warsaw, 2009, p.58.

<sup>9</sup> Vide supra p.58.

<sup>10</sup> I. Leśnikowska-Matusiak, A.Wnuk, *Wpływ hałasu komunikacyjnego na stan środowiska akustycznego człowieka*, 2014, p.50.

The problem of noise generated by air transport operation, not only has a direct, negative impact on humans, as main beings functioning in the environment, also affects the economy through a decline in property prices. Next consequences may be degradation of workers performance by reducing their effectiveness. Exposure of beings to permanent noise impacts, can generate the cost of treatment required to eliminate the disease caused by this unwanted sound - these are the indirect economic effects affecting man, who is one of the most important entities living in the environment.

Noise has huge impact on the loss of silence by the elements of the environment. It is causing limiting and reducing the value of the recreational or medicinal places, as well as changing the behaviour of animals, for example re-location of habitats and birds ( and also reducing the number of eggs submitted by them)<sup>11</sup>. There is also another problem, despite the strong noise emitted by aircraft, there is a significant probability of collision with birds, on and over the runway, and, even during flight, at high altitudes. Low-flying birds, for example gulls and terns are exposed to collisions with planes landing or taking off. Others, for example eagles, often are looking for food in the region where flight operations are carried out. The issue of noise at night, by air traffic (as well as road and rail), has a negative impact on bats. Their hunt take place after dark, and their flights are at low altitudes. For them any movement constitutes a major obstacle to find food<sup>12</sup>.

Noise has always existed, but the value of sound for which humans are exposed in recent years has increased. Allowing for such an increasing emissions of harmful noise affecting the individual elements of the environment, can cause a lot of damages. The disorder in described by Maslov hierarchy of human needs, is not the only problem. Change of the limits of sound influencing and threatening to humans and other living creatures in their environment, in the future may even have a decisive impact on the life processes of individual entities operating in that environment.

## 2. SOLUTIONS FOR DECREASING THE NOISE EMITTED BY AIR TRANSPORT

Reducing and taking action aimed to reduce the negative impact of noise produced by the performance of air transport on the environment, may take the form of passive (minimizing the effects of noise) or active (noise reduction at source). Removing the causes in order to reduce the effect of noise is usually carried out within the drive systems of vehicles and dealing with the consequences, within the airport. Planning and airspace's management, analysis of operational procedures and operational restrictions, which are focused primarily on increasing efficiency in cost, are another possible solutions and ways to reduce negative impact of noise. Although, attempts to eliminate the problems, active and passive, should be done in a sustainable way.

The existing airport through its activities may affect the health of people living nearby by the negative impact of noise. Limiting and reducing its impact is very important, therefore, there are taking many steps to minimize the undesired noises. Simple and often used solutions are special embankments or green areas placed between the noise source and a protected environment.

---

<sup>11</sup> *Hałas w środowisku. Zanieczyszczeniem środowiska hałasem* [online]  
<http://www.ekologia.pl/srodowisko/ochrona-srodowiska/halas-jest-zanieczyszczeniem-srodowiska,5252.html>

<sup>12</sup> M. Milczarek, *Wpływ budowy lotniska Modlin i infrastruktury wokół na środowisko naturalne*, p. 58-62.

One of the most popular solutions to stop the high-pitched sound is to set between the airport, which is a source of noise, and areas inhabited, are acoustic screens<sup>13</sup>. It creates a barrier for sound waves, because it is reflecting and even is partially absorption them. According to the studies, that kind of the obstacle, measuring 6 meters height, is able to reduce noise, reaching to residents of nearby areas, up to 12 dB<sup>14</sup>.

Important is planning the village in prior, which is aimed to, among others, limit the impact of noise on existing and future residents<sup>15</sup>. Very often, in such projects are allocated the zones with acceptable heights of sound that may arise to those areas<sup>16</sup>. In such projects, the future airport's construction it is rarely included. The authorities and engineers planning such an object must reckon with and follow certain restrictions on certain territory during processes connected with construction, building and maintenance of an aerodrome.

Protection barriers for reducing noise should be taken into account during the design process of buildings within the airport and beyond. Use for the construction of residential, business and service (which is airport included) buildings new technologies, which are characterized by better indicators of sound insulation, comparing to those in older buildings, new windows for better insulation, makes for staying inside these objects people, and their hearing organs, huge difference in height of sound. Distribution of individual buildings within the airport also has a large impact on occupants, who are e.g. in the arrivals/ departures hall. Placing such objects behind another, higher, which do need not be protected from noise (e.g. hangar), can contribute a reduction in the sound between 5 and 25dB<sup>17</sup>.

At the airport, in order to reduce the impact of noise nuisance to passengers and staff, buildings located in the closest places to service station for aircrafts are designed in such order to direct the outlets of engines in an opposite direction to those objects<sup>18</sup>. This solution reduces the amount of the sound which is reaching the interior areas. Using appropriate materials for the construction of roads and movement areas for planes at the airport, such as low-noise, also has the impact and positive effect onto lowering the noise while moving across those surfaces<sup>19</sup>.

The noise generated by vehicles, used at the airport, can also be reduced through exploitation of vehicles that are in good condition, have electric or hybrid drive, which are equipped with special, approved tires<sup>20</sup>. Noise reduction through quoted solutions may be even between 7-10 dB<sup>21</sup>.

Protection of people from noise nuisance, can also be achieved by requiring the use, by workers and the long-term staying people on the territory of the airport, of hearing protectors such as inserts, ear muffs, safety helmets. The use of anti-vibration protection and protectors allows to reduce the amount of sound and its negative impact on the health and people's lives<sup>22</sup>.

---

<sup>13</sup> Z. Engel, *Ochrona przed drganiem i hałasem*, Warsaw, PWN 1993.

<sup>14</sup> <http://dlapilota.pl/wiadomosci/technologie/szum-skrzydel-i-ryk-silnika-o-halasi>

<sup>15</sup> *Ocena możliwości zastosowania aktywnych metod redukcji hałasu w transporcie drogowym*, p.34-37.

<sup>16</sup> F. Tomaszewski, *Oddziaływanie hałasu lotniczego na środowisko*, Wydawnictwo Politechniki Krakowskiej, 2012 p.314-316.

<sup>17</sup> *Ocena możliwości zastosowania aktywnych metod redukcji hałasu w transporcie drogowym*, p.34-37.

<sup>18</sup> T. Kijewski, *Samolot a środowisko – hałas i emisja spalin*, Politechnika Rzeszowska, Rzeszów 2002, p. TK -2- TK-6.

<sup>19</sup> Z. Józwiak, *Metody ograniczania hałasu komunikacyjnego w aglomeracjach miejskich*, Szczecin, 2011.

<sup>20</sup> Z. Józwiak, *Metody ograniczania hałasu komunikacyjnego w aglomeracjach miejskich*, Szczecin 2011.

<sup>21</sup> Biuro analiz i dokumentacji, Zespół Analiz i Opracowań Tematycznych, *Zagrożenie hałasem Wybrane zagadnienia*, Kancelaria Senatu, February 2012, p.22-23.

<sup>22</sup> E. Pyłka-Gutowska, *Ekologia z ochroną środowiska*, Wydawnictwo Oświata, Warsaw, 1996, p. 172-173.

Doing surveys, checking aircraft engines are among the necessary steps before performing a safe flight operations. Unfortunately, these are counted as very noisy processes. Due to the huge noise while those processes, such attempts are not made at the airport, but within a special technical base<sup>23</sup>.

Standards and law restrictions also have an impact on reducing the negative impact of high sounds on society. Often are determined specific areas for which air traffic is prohibited. Closing or set a limit on flight operations in the rush hours on the specific runway, lack of agreement on night operations are ways to minimize this problem through political measures<sup>24</sup>. Although these solutions can negatively influence the airport capacity, contribute bigger traffic at the airport, causing delays of aircraft and generate higher operating costs for airlines. Anyway the aim of these regulations is a protection, welfare and comfort of society<sup>25</sup>. Including the noise reduction in law, and make some restriction about limits of emitted noise is a kind of solution for forcing the organisations, airlines etc. to make some steps towards decreasing the unwanted sound emission to the environment<sup>26</sup>.

The demarcated areas of acceptable noise heights are not only affecting the earth's surface, they also must comply with aircraft moving across the sky. Procedures for taking-off and landing normally have chosen flight path. They are picked in way, to reach as high altitude during those operations of the aircraft, to protect areas and continued its flight with a minimum noise emission reaching the earth's surface. Above the little built-up areas, parks, forest areas etc. shall be determined also minimum noise routes, which cover the routes between the airport and the air corridor, without influencing negatively by unwanted sounds on living beings<sup>27</sup>.

During the flight, the main source of noise reaching the environment is primarily aircraft's engine. Its components which emit ambient sounds are the nozzle inlet, nozzle outlet and compressor (or fan in the case of an engine turbofan). The design of the air intake, can actively minimize noise by suitable directing the flow of gas, and lead to disruption of its flow through the extension of the inlet<sup>28</sup>.

The sound emitted by mixing an enormous speed fumes flying out from the exhaust outlet with the air, surrounding the plane, belongs to one of the loudest, arising from the working aircraft processes. This noise largely depends on the speed difference between those two substances, so if the speed of the aircraft is higher, the smaller is the noise<sup>29</sup>. Unfortunately, this rule does not have much meaning for people living and staying close to the airport. During taking-off and landing, plane's speed, and general, during movement of planes at the airport is not high. To solve this problem for one-flow engines can be the reduction of the speed of the exhaust through maximum opening adjustable nozzle. For other engines, a constant flow rate would mean decline over. In turbofan engines the discharge of speed reduction is possible through two approaches. Both include ejectors of the additional air flow<sup>30</sup>.

---

<sup>23</sup> T. Kijewski, *Samolot a środowisko – hałas i emisja spalin*, p. TK -2- TK-6.

<sup>24</sup> R. Łaski, *Zagrożenia i zapobieganie degradacji środowiska naturalnego na lotniskach*, Warsaw 2000, str.29.

<sup>25</sup> Presentation of Gavin Eccles, *Aviação Verde - Noise Pollution & Local Air Quality*.

<sup>26</sup> Federal Aviation Administration, *Aviation Emissions, Impacts & Mitigation: A Primer*, Office of Environment and Energy, 2015, p.10-13.

<sup>27</sup> T. Kijewski, *Samolot a środowisko – hałas i emisja spalin*, Politechnika Rzeszowska, Rzeszów 2002, p. TK -2- TK-6.

<sup>28</sup> <http://dlapilota.pl/wiadomosci/technologie/szum-skrzydyl-i-ryk-silnika-o-halasi>

<sup>29</sup> J. Anderson, *Aircraft performance and design*, WCB/McGraw-Hill, 1999, p.162-164.

<sup>30</sup> P. Głowacki, *Zagrożenia ekologiczne wokół lotnisk i możliwości ich ograniczania*. p.9.

The air supply to the interior of the engine is subsequently divided into smaller streams of exhaust gas and mixed with applied gas, that is the first solution<sup>31</sup>. Another way, is to mute the drive plane's element by passing air through the motor housing, which then will surround the faster, heated, coming from the inside of the exhaust, gases. These methods belong to the mechanical silencers. All make the lower velocity of harmful substances, and the motor's noisiness is reduced by 15-17 dB<sup>32</sup>. In the case of the impossibility of implementing such solutions, which usually work only on newer models of aircraft, can be used airport carriage silencers<sup>33</sup>. Such devices are substituted into the inlets and outlets of jet engines. That solution is a passive reduction of noise pollution, which is coming from the airport to the nearby areas.

Noise from the operation of the compressor and the fan can be reduced by getting the lowest speed of these working elements. The use of the triple-rotor engine, for which it is possible to change the fan speed during landing operations, can reduce noise by 3-4 dB<sup>34</sup>.

For airplanes that have reciprocating engines, reducing the noise produced by the working element can be achieved by using two-phase injection. Preceding the proper dose of fuel injection reduces the high increase of pressure, and reduces the noise as well.

In the case of helicopters and turboprops planes as well, the reason of noise is mainly the work of the propeller, and quite often, in multi-engine airplanes the lack of synchronization. Proper setting and the slope of propellers and their synchronization are most common ways of reducing the noise which reach the airport and its surroundings. After applying these solutions, people on board of the aircraft can enjoy more their travel. The frequency of sound produced by the propeller is higher and more badly tolerated by the human organ of hearing, comparing with the sounds produced by the turbojet's airplanes<sup>35</sup>.

Introduction of solutions aimed to make quieter elements of the airframe, also reduces the noise emitted by air transport. Unfortunately, those elements are more difficult to change and decrease their sounds comparing to the mute drive<sup>36</sup>. Manufactures which are using new technology during the process of building the aircraft can influence on the sound reduction, e.g. as a result of release the landing gear, opening covers and other wing's mechanization.

Introduction of the new parts of the airframe, which are decreasing the drag (is also a source of noise), is the solutions for lower, negative impact of the noise which reaches to the environment<sup>37</sup>.

Few years ago, the scientist had counted that there are some mathematical models of several aero- acoustic mechanism to mute the sound<sup>38</sup>. Nowadays it is much easier. The industry had figured out some new and easier to implement solutions. One of them is to mute the sounds from sources different than the drive.

---

<sup>31</sup> J. Anderson, Aircraft performance and design. Wydawnictwo WCB/McGraw-Hill, 1999, p.170-174.

<sup>32</sup> T. Kijewski Samolot a środowisko – hałas i emisja spalin. Politechnika Rzeszowska, Rzeszów 2002, p. TK -2- TK-6.

<sup>33</sup> T. Kijewski Samolot a środowisko – hałas i emisja spalin. Politechnika Rzeszowska, Rzeszów 2002, p. TK -2- TK-6.

<sup>34</sup> Vide supra p. TK -2- TK-6.

<sup>35</sup> Vide supra p. TK -2- TK-6.

<sup>36</sup> Vide supra p. TK -2- TK-6.

<sup>37</sup> Federal Aviation Administration, Aviation and Emissions, A Primer, Office of Environment and Energy, 2005, p.18-21.

<sup>38</sup> D. Casalino, F. Diozzi, R. Sannino, A. Paonessa, Aircraft Noise Reduction Technologies: A Bibliographic Review," Aerospace Science and Technology, 2008, Vol. 12, No. 1, p. 1–12.



Designers of airplanes are trying to interference of acoustic waves. Mutual depriving of the kinetic energy by the waves cause that the noise produce by them is much lower<sup>39</sup>.

Complete removal of the noise made in order of air transport is impossible. As a result of each component, transmissions etc. will always be output in the form of acoustic wave's sound. Although the changes and efforts to reduce noise in one working area of aircraft may cause a dangerous rise in another. There are different active and passive ways of limitations of noise, without compromising and making the decrease of sound within other systems<sup>40</sup>. The introduction and use of new technologies, as well as technological solutions, in the fight against noise, has an impact on the reduction, and what is more, reducing the negative impact of air transport through unwanted, high-pitched sound on the environment<sup>41</sup>. Changes and protection against noise resulting from air transport is a priority for the European Union. In its key program, "Clean Sky" as a priority, it is adopted that should be made 50% reduction in noise<sup>42</sup>. Such reduction is possible. Use of mentioned in this work arrangements can make a reduction in the emission of noise coming from the air transport, by 33%, through the change in engine design, after changes in the design of the airframe and the performance of air operations with better procedures decrease of noise may reach 24%<sup>43</sup>.

## REFERENCES

- [1] Annex number XIV to the Chicago Convention from 17 of December 1944.
- [2] C. Lim, J. Kim, J. Hong, S. Lee, *Effect of Background Noise Levels on Community Annoyance from Aircraft Noise*, Journal of the Acoustical Society of America, 2008, Vol. 123.
- [3] C. Sequeira, *An Assessment of the Health Implications of Aviation Emissions Regulations*, Master of Science Thesis MIT, 2008.
- [4] D. Casalino, F. Diozzi, R. Sannino, A. Paonessa, *Aircraft Noise Reduction Technologies: A Bibliographic*, Review, Aerospace Science and Technology, 2008, Vol. 12, No. 1.
- [5] E. Pyłka-Gutowska, *Ekologia z ochroną środowiska*, Wydawnictwo Oświata, Warszawa, 1996.
- [6] Federal Aviation Administration, *Aviation Emissions, Impacts & Mitigation: A Primer*, Office of Environment and Energy, 2015.
- [7] Federal Aviation Administration, *Aviation and Emissions: A Primer*, Office of Environment and Energy, 2005.
- [8] F. Tomaszewski, *Oddziaływanie hałasu lotniczego na środowisko*, Wydawnictwo Politechniki Krakowskiej, Kraków 2012.
- [9] I. Leśnikowska-Matusiak, A. Wnuk, *Wpływ hałasu komunikacyjnego na stan środowiska akustycznego człowieka*, 2014.
- [10] J. Anderson, *Aircraft performance and design*, WCB/McGraw-Hill, 1999.
- [11] K. Gradkowski, *Sposoby częściowej redukcji hałasu transportu miejskiego. Transport miejski i regionalny*. Politechnika Warszawska, 2009.
- [12] M. Jeż, *Lotnictwo a zrównoważony rozwój*, Biblioteka Naukowa Instytutu Lotnictwa, Warszawa, 2009.
- [13] M. Leśka, M. Pasek, *Porty lotnicze*, Wydawnictwo Politechniki Śląskiej, Gliwice 1997.
- [14] M. Milczarek, *Wpływ budowy lotniska Modlin i infrastruktury wokół na środowisko naturalne*, Warszawa.
- [15] *Ocena możliwości zastosowania aktywnych metod redukcji hałasu w transporcie drogowym*.
- [16] Presentation of Gavin Eccles, *Aviação Verde - Noise Pollution & Local Air Quality*.
- [17] P. Głowacki, *Zagrożenia ekologiczne wokół lotnisk i możliwości ich ograniczania*.
- [18] R. Łaski, *Zagrożenia i zapobieganie degradacji środowiska naturalnego na lotniskach*, Warszawa 2000.
- [19] S. Zajas, D. Ozga, *Lotnictwo a środowisko naturalne*, AON, Warszawa 2011.

<sup>39</sup> <http://dlapilota.pl/wiadomosci/technologie/szum-skrzydel-i-ryk-silnika-o-halasio>

<sup>40</sup> P. Głowacki, *Zagrożenia ekologiczne wokół lotnisk i możliwości ich ograniczania*. p.9.

<sup>41</sup> M. Leśka, M. Pasek, *Porty lotnicze*. Wydawnictwo Politechniki Śląskiej, Gliwice 1997, p.36.

<sup>42</sup> <http://www.cleansky.eu/content/homepage/aviation-environment>

<sup>43</sup> M. Jeż, *Transport lotniczy a zrównoważony rozwój*. Biblioteka naukowa Instytutu Lotnictwa, Warszawa, 2009, p.46.

- [20] T. Kijewski, *Samolot a środowisko – hałas i emisja spalin*, Politechnika Rzeszowska, Rzeszów 2002.
- [21] Z. Engel, *Ochrona przed drganiami i hałasem*, Warszawa, PWN 1993.
- [22] Z. Józwiak, *Metody ograniczania hałasu komunikacyjnego w aglomeracjach miejskich*. Akademia Morska w Szczecinie, Szczecin.
- [23] *Zagrożenie hałasem Wybrane zagadnienia*, Biuro analiz i dokumentacji, Zespół Analiz i Opracowań Tematycznych, Kancelaria Senatu, 2012.
- [24] *Hałas w środowisku. Zanieczyszczeniem środowiska hałasem* [online] <http://www.ekologia.pl/srodowisko/ochrona-srodowiska/halas-jest-zanieczyszczeniem-srodowiska,5252.html>
- [25] *Aviation & Environment* [online] <http://www.cleansky.eu/content/homepage/aviation-environment>
- [26] *Hałas w środowisku. Zanieczyszczeniem środowiska hałasem* [online] <http://www.ekologia.pl/srodowisko/ochrona-srodowiska/halas-jest-zanieczyszczeniem-srodowiska,5252.html>
- [27] *Szum skrzydeł i ryk silnika – o hałasie* [online] <http://www.dlapilota.pl/wiadomosci/technologia/szum-skrzydel-i-ryk-silnika-o-halasio>

## METHODS OF DIGITAL IMAGE PROCESSING

Ivan STEFANOV, Ivan DIMITROV

"Vasil Levski" National Military University, Faculty of Aviation, Bulgaria  
(isstefanof@gmail.bg, mins@mail.bg)

**Abstract.** *Image quality is influenced by distortion, brightness and contrast of the resulting images. Understanding the histogram is perhaps the most important element when working with images. The histogram shows whether exposure of the image is correct or whether the light is soft or hard and what changes need to be taken in order to get a better image.*

**Key Words:** *histogram, improve quality of images, contrast, brightness*

### 1. INTRODUCTION

Methods of digital image processing have found wide application in industry, the arts, medicine, space and ecology. They apply to the management of automated processes for detecting and tracking objects, pattern recognition and so on.. The formation of images, enhancing their quality and the automated processing of aerial images, including images taken from satellites, UAVs, radars with synthetic aperture and so on.. are subject to a number of research and development [11]. The automated analysis widely used systems for remote sensing (monitoring) sites, forests, such as the calculation of the area of damage to monitor harvest in intelligence and system for fire safety. Despite the diversity of cases that are created and recorded images, they can be described using a general mathematical formalism.

### 2. STATEMENT. A STUDY OF ALGORITHMS FOR ENHANCING THE CONTRAST OF OPTICAL AND RADAR IMAGES

Not only the distortions but the image quality is influenced also by the brightness and contrast of the resulting images. One of the most used methods to improve the image quality is by increasing the contrast. Since these methods redistribute levels of brightness set dynamic range, then their application to color images are associated with some peculiarities.

In the report are represented three research algorithms that enhance the contrast of images. The first is consist of expanding the dynamic range of luminance in the entire image. The second one uses histogram image processing which is aimed to maximize uniform histogram. The third algorithm is adaptive, as in it the algorithm to uniformly histogram is applied to the individual portions of the image, not to the entire image.

Researches and estimates are made based on an experiment with real flight of UAV "Hawk - 2 MB "produced in Bulgaria. It has optical camera on board.

The image quality is influenced by the perturbations, brightness and contrast of the resulting images. Some of the most used methods for improving image quality are those who increase the contrast. As they expand the dynamic range of brightness levels, the application of color images involves some peculiarities.

Further are showed the test results of three algorithms for enhancing the contrast of images.

One of the algorithms performs expanding of the dynamic range of luminance in all images.

For this purpose function is used:

$$s = T(r) = \frac{1}{1 + (m/r)^E},$$

where "r" is the brightness of the input image, s- the corresponding brightness of the source image and parameter "E" controls the slope of the function. In the second algorithm is used histogram of the image. By processing it is aimed to be attained the maximum possible histogram. Histogram of the digital image is the number "L" of possible brightness levels lying in the range of  $[0, G]$  and a discrete function being is defined:

$$h(r_k) = n_k,$$

where  $r_k$  is  $k$ -*th* level of brightness in the interval  $[0, G]$ ,  $n_k$  - the number of pixels of the image, which brightness level is equal to  $r_k$ . It is convenient to work with a normalized histogram, which is obtained by division of the elements  $h(r_k)$  of the total number of pixels of the image, which is designated  $n$ :

$$p(r_k) = \frac{h(r_k)}{n} = \frac{n_k}{n},$$

at  $k = 1, 2, \dots, L$ . Taking into account the probability theory, the number  $p(r_k)$  is the probability (frequency) to appear (present) level of intensity  $r_k$  in an image.

The third algorithm is adaptive. In it leveled histogram method is applied to some sections of the imagerather than entire image.

This method is generally very simple. Discussed are continuous parameters in the range of  $[0, 1]$ . Indicate with  $\mathbf{r}$  and  $\mathbf{z}$  the levels of brightness of the input and output images, respectively. The input levels are characterized by a probability density function  $p_r(r)$ , and the output image- by a probability density function  $p_z(z)$ . It is known that the transformation

$$s = T(r) = \int_0^z p_r(\omega) d\omega,$$

defines the brightness  $s$  at the levels, which have a steady density distribution of the probability  $p_s(s)$ . It is defined a variable  $\mathbf{z}$ , argument of the spectral function of the impact assessment where is valid the following equation

$$H(z) = \int_0^z p_z(\omega) d\omega = s.$$

Bearing in mind that the resulting level of brightness must have a density  $p_z(z)$ , follows:

$$z = H^{-1}(s) = H^{-1}[T(r)].$$

Using the function  $T(r)$  can be calculated in the input image.

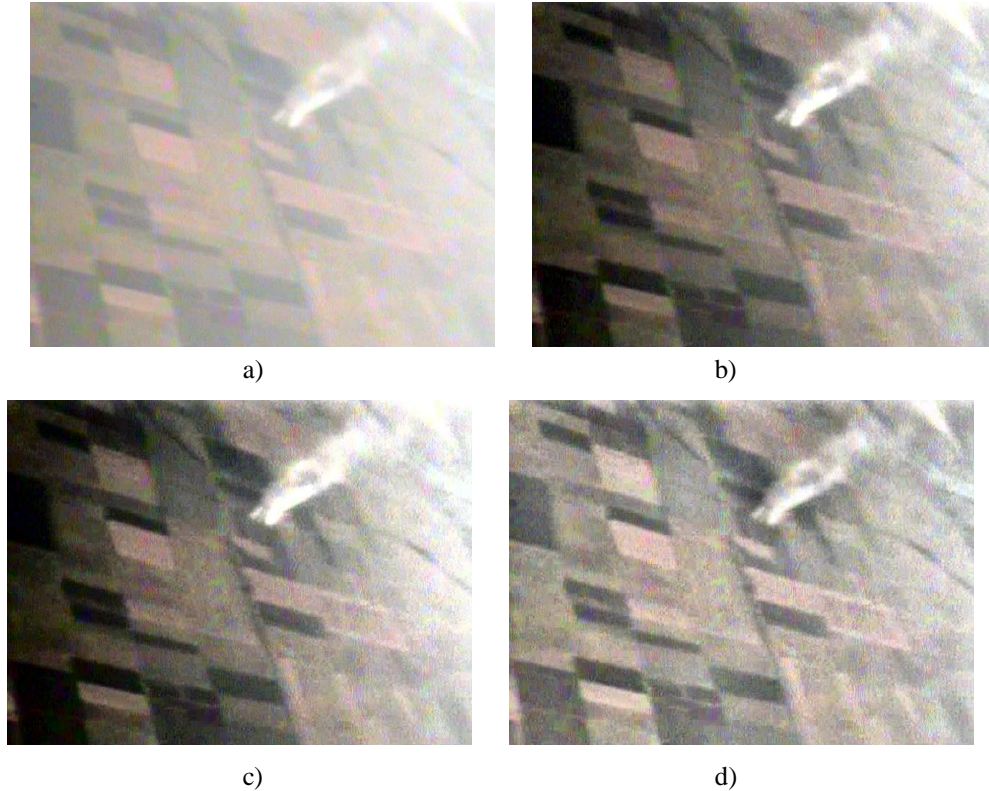
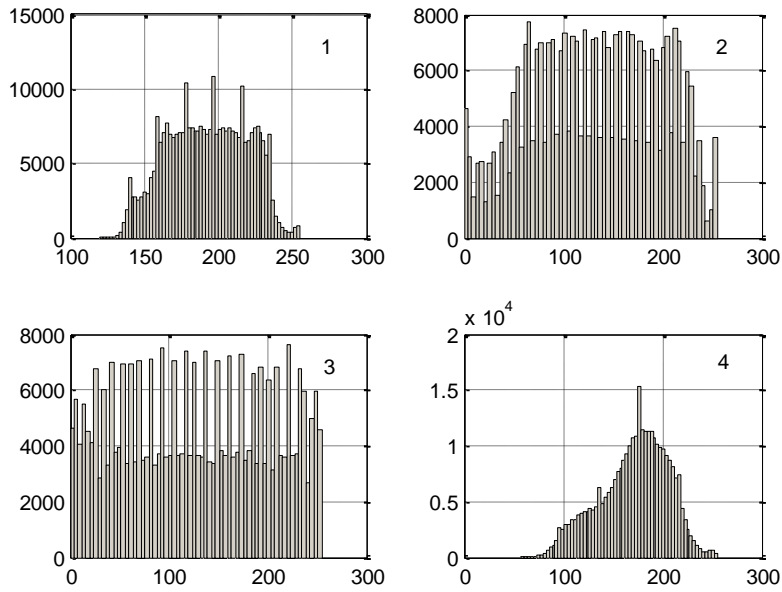

**FIG.1** Examination of the algorithms for contrast enhancement in optical imaging.

Figure 1 shows the results of the processing of optical image obtained by the video camera located on board the UAV, using the three methods - extending the dynamic range (Fig. 1 b), a steady a histogram (Fig.1, c) and the adaptive method (Fig. 1, d). From the figure it is seen that in the linear expansion of the range of the image is darker.

In the method of the uniform histogram darker areas are smaller, but there are areas of saturation (very bright regions), which may lead to the masking of the objects that are present there.

The image obtained by processing in the adaptive method is with the highest quality and allows the most preferably to be distinguished details on the image.



**FIG.2** Histograms of the output and processed images

Besides visual analysis of the images are analyzed and the histograms of the images. Figure 2 shows histograms of the output image (Chart 1), resulting in the expansion of dynamic range (Chart 2), the image obtained by the algorithm of the regular histogram (Chart 3) and the image obtained using the adaptive algorithm (Chart 4). From the figure it is seen that in the histogram of output image has overshoots.

In the histograms of the images processed by the algorithm to extend the dynamic range and a uniform histogram also are observed overshoots. Moreover, in these histograms have the values and at lower brightness levels, which explains the presence of dark areas in the respective images.

At the adaptive method absent overshoots in the histogram and also are missing values with low luminance. This explains the lack of dark areas in the resulting image. Output image in Figure 1 has a fairly low quality as it is not shooting with specialized high quality camera.

Studies to increase the contrast of optical image shows that the best results are obtained by using the adaptive algorithm.



a)



b)

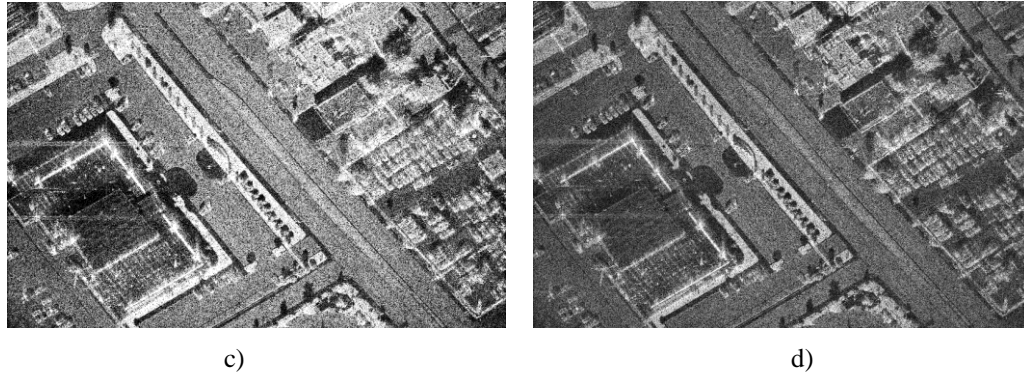

**FIG.3** Study of algorithms to enhance contrast in images from SAR

These three algorithms are applied of image processing derived from a synthetic aperture radar(SAR). Figure 3 shows the results of increasing the contrast of image SAR.

The results show that the use of the algorithm for expanding the dynamic range gives better results than in optical images, but again there are more dark areas.

Using the algorithm of the uniformly histogram again there are areas of saturation, which further reinforces the manifestations of speckle - effect typical for radar images.

Figure 4 shows the histograms of the output image (Chart 1), resulting in the expansion of dynamic range (Chart 2), received by the steady histogram algorithm (Chart 3) and obtained using adaptive algorithm (Chart 4). It is seen that the histogram of output image is much narrower than that of the optical and is concentrated in the low luminance. This explains why the output image is dark.

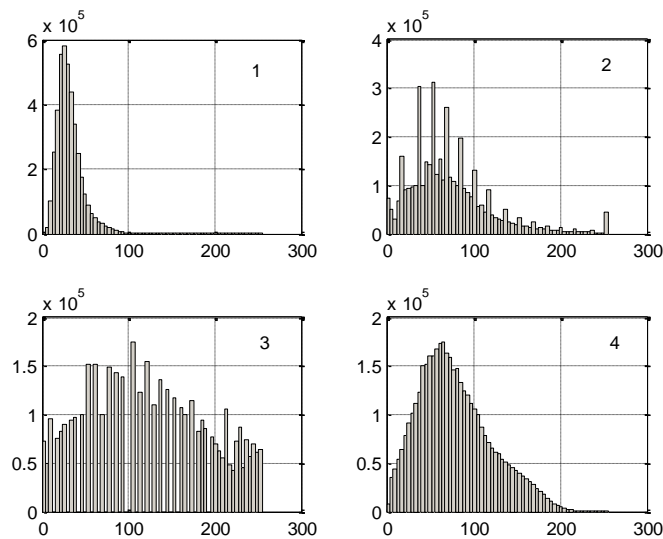

**FIG.4** Histograms of the output and processed images

Despite strong focused histogram of the source image at the the histograms of images, obtained after processing algorithms to expand the dynamic range and a uniform histogram, overshoots occur.

While in the algorithm of the uniformly histogram there are relatively large values of the histogram in the field of high brightness , in the algorithm in the enlargement of the dynamic range, they are significantly smaller.

This explains the higher quality of the received image after expanding the range than the application of the algorithm with optical images.

The histogram of the image obtained by adaptive processing, there are no overshoots and considerable values in high luminance. This explains the fact that the images obtained by this algorithm are with the highest quality.

### 3. CONCLUSIONS AND SUGGESTIONS

Based on the studies and the results obtained can be summarized that whether the images are optical or radar, best suited for contrast enhancement is adaptive algorithm.

### REFERENCES

- [1]. Грузман И. С., Киричук В. С., Косых В. П., Перетягин Г. И., Спектор А. А., Цифровая обработка изображений в информационных системах. – Учебное пособие.- Новосибирск: Изд-во НГТУ, 2000. - 168.
- [2]. Теодора Ив. Петрова, Марин С. Маринов, Монографичен труд „Методи и алгоритми за обработка на аерофото и радиолокационни изображения, улесняващи анализа на информацията“, Плевен 2013 г.



## ASPECTS REGARDING INNOVATIVE SPACE THRUST SYSTEMS

**Daniel Ion ULARU**

”Henri Coanda” Air Force Academy, Brasov, Romania (ularu\_daniel@yahoo.com)

**Abstract:** *The idea of space travelling has concerned people since decades. After putting these ideas in practice, scientist observed that there are many problems and many unknown possible bad things that could appear up there. The main difficulty is still finding a thrust that could go beyond the heliopause. Regarding that, the purpose of this project is to highlight the best way of space travel thrusters. There is also a comparison between two other concepts of space travel.*

**Keywords:** thrust, ionic engine, solar-sail, propulsion.

### Acronyms

AU	Astronomical Unit [3]	NIAC	NASA Innovative Advanced Concepts
NASA	National Aeronautics and Space Administration	USD	United States Dollar
HERTS	Heliopause Electrostatic Rapid Transport System	NSTMD	NASA’s Space Technology Mission Directorate

### 1. INNOVATIVE CONCEPTS & PROJECTS ALONG THE TIME.

The oldest man-made flying objects could be considered kites made by the year 200BC, of course the main objective was military – Surveillance of the enemy territory. Starting from 1400 when Leonardo DaVinci was making the first drafts regarding flying machines up to ionic thrusters a great evolution is clearly visible, see Figure nr.1 [1]



**FIG.1** Thrusters evolution (a ornithopter, b ionic thruster), [1, 2]

The word “Aviation” appeared in 1863 when Frenchman Guillaume Gabriel Joseph from Landel published the magazine “Aviation ou Navigation Aeriennne”. [6]

Only at the beginning of the 20<sup>th</sup> century it was proved that it is possible to build a flying machine heavier than the air. The thrust based on propeller began in 1874 and continued until the 1900s when the jet engine was being studied. After the appearance of the jet engine in 1930 and its testing by Frank Whittle in 1941, the launch of an object on the orbit using jet thrust was just a step away (1957). Since then people have looked for different methods of a more efficient thrust.[4, 8].

## 2. ACTUAL INNOVATIVE CONCEPTS AND PROJECTS

### 2.1. *Ionic Thruster*

Currently, the ionic thruster engine is the most innovative method of space travelling, but the main inconvenience is that the ionic engine is limited by the maximum lifetime of the thrusters chosen, about 5AU, see Figure nr.2.

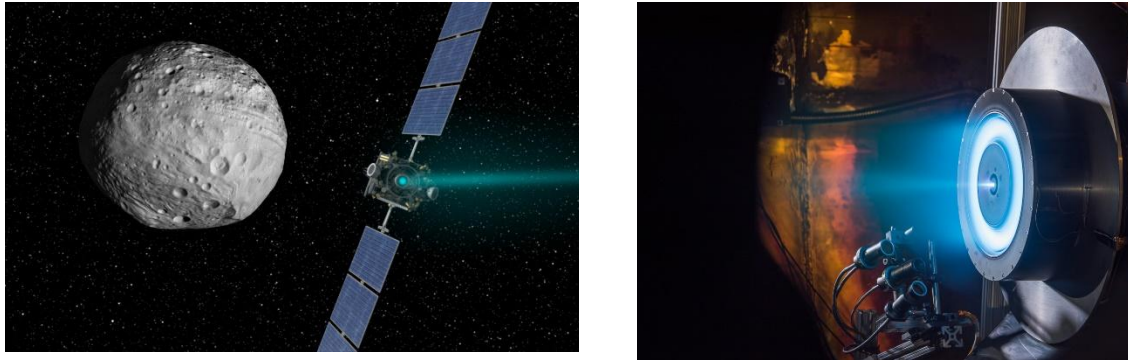

**FIG.2** Ionic Thruster

### 2.2. *Solar sail- “LightSail”*

Another innovation such as ionic thruster is the solar sail system, in which the solar wind is used as thrust, similar with the sailing wind that is used with air currents, see Figure nr.3 [7]

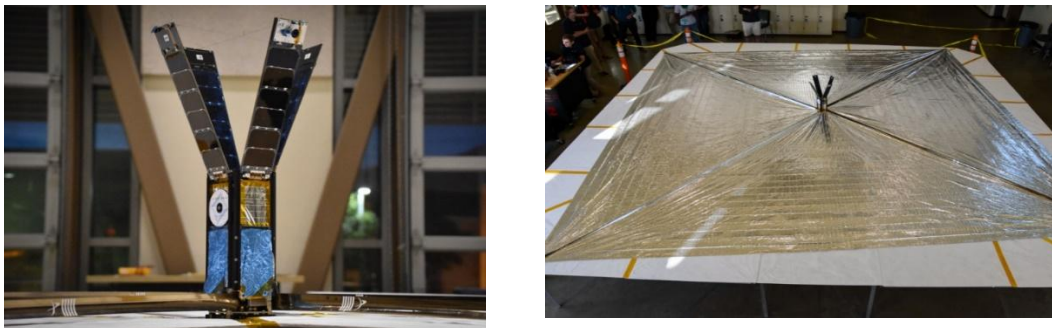

**FIG.3** Transport system, Solar Sail.

The disadvantages are similar to those of the ion thrust engine, the maximum acceleration distance is about five astronomical units, but at Planetary Society the scientists have already created a project named “LightSail” which is still in progress but it was subjected to numerous tests.

There are already numerous animations but also physical projects and scale models similar with the actual project that will be sent in space. They claim that they have all the necessary things for a real launch in space.

The only impediment to the Planetary Society is the fact that they are a non-profit team and this thing is felt in the testing and development budget.

The latest innovation from N.A.S.A. is the E-sail propulsion system used in electrostatic rapid transport system (HERTS), which appears to be the best way to maintain propulsion to the heliopause. There are also advantages and disadvantages which are going to be detailed, see Figure nr.4.

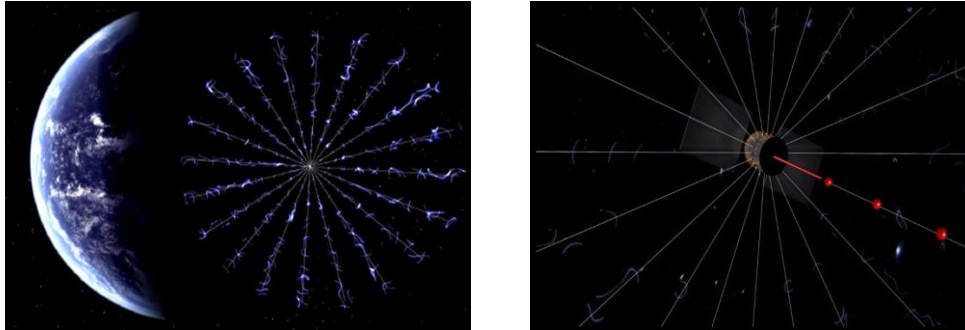

FIG.4 HERTS system

### 3. HELIOPAUSE ELECTROSTATIC RAPID TRANSPORT SYSTEM (HERTS)

Tests began at NASA center in Huntsville, Alabama, being a revolutionary concept, a propulsion system that could send spacecraft to the edges of the solar system, the heliopause, faster than anything else.

The tests results provided data about on how the modeling of HERTS should be and created a better image of it. The proposed HERTS E-sail concept, a propellant-less propulsion system, would harness the solar wind to travel into interstellar space.

Marshall advanced concepts office's engineer, Bruce Wiegmann, also principal investigator for HERTS E-sail system, claim that the sun releases protons and electrons in the solar wind at high speeds, about 400-750 kilometers per hour.

Starting from the center, the aircraft propulsion system consists of 10 to 20 aluminum bare wires, electrically charged. These wires would produce a high E-sail circular energy, which would reject electrostatic protons traveling with the solar wind at the same speed, making momentum transfer and gaining thrust.

The most important and also difficult to make is that each tether should be extremely thin, only 1 millimeter, the width of a standard paperclip, and very long, about 12 and a half miles (20km), almost 200 football fields. The centrifugal forces will stretch the tethers into position, as the spacecraft slowly rotates at one revolution per hour.

The tests are taking place in the testing systems of high intensity solar environment, which is designed to examine the rate of collisions between protons and electrons and positively charged wires.

In a controlled environment, largely plasma, which mimic the plasma found in space, the testing team is using a stainless-steel wire as a replacement for the lightweight aluminum wires, which would be used in space.

Although stainless steel is denser than aluminum, the non-corrosive properties would perfectly mimic aluminum used in space and would allow more tests without stainless steel being degraded.

The engineers are measuring the embettlement of protons in the aluminum wire under tension in a room to improve data about modeling, which will be increased and applied to the future technology E-sail.

The tests are also measuring the number of electrons attracted by the wires. This data will be used in the technical specification for the electron emitter that expel the excess electrons from the spacecraft to maintain essential positive voltage of the wire, which is completely necessary, “critically” for the proper functioning.

This concept is based on the Dr.Pekka Janhunen of the Finnish Meteorological Institute’s invention , and also on the current technologies required for a propulsion system like E-sail type.

If the results of the plasma modeling test and the way the aluminum wires are launching are promising, after an investigation of nearly two years, it would have still be needed a lot of work to design and build this new concept. Perhaps this propulsion system will be used practically in at least a decade from now.

HERTS E-sail concept is being studied at the National Academy of Sciences since 2012.A study realized by experts at NASA, NASA industry, academic environment and government agencies have identified this advanced propulsion system as the main obstacle for exploring the heliosphere of the solar system in the near future.

The survey had provided a map of the heliophysics community priorities for the years 2013-2022. It highlighted the need for a propulsion system that could reach the edges of the heliosphere to the heliopause at a speed significantly faster than any other system with the same objective.

For sending a probe in space, a journey in deep space, E-sail should have a very large effective surface, as the journey is measured in astronomical units, E-sail should be about 232 square miles effective surface, an area slightly smaller than the city of Chicago.

The useful surface at a distance of 5 astronomical units would increase by more than 463 square miles, an area similar to the city of Los Angeles. This increasing in surface would result in a such a great acceleration that is impossible to compare with any other available method of propulsion.

For example, when the spacecraft reaches the asteroid belt at about 5 astronomical units, solar photons are dissipated and acceleration becomes zero. These concerns do not apply in the case of solar wind protons. With the continuous flow of protons, and very high effective surface, E-sail will continue to accelerate up to 16-20 astronomical units, at least three times farther than propulsion that uses solar sail or ionic thruster. This will also create much higher speeds.

In 2012, Voyager 1, NASA’s spacecraft, became the first spacecraft which ever passed the heliopause and reached interstellar space. Launched in 1977, Voyager 1 took almost 35 years to make the fascinating journey of 121 astronomical units. HERTS goal is to develop an E-sail propulsion, which could make the same travel distance, but three time faster than Voyager 1.

NASA research has showed that such a concept, method of propulsion, could travel to the heliopause in less than 10 years, this would revolutionize the scientific domain and space missions.

The development and the testing of HERTS E-sail is funded by NASA's Space Technology Mission Directorate (NSTMD) through the NASA Innovative Advanced Concept (NIAC), which encourages any ideas that could transform future mission by creating radical concept, better than any current project or completely new in aerospace domain. NIAC project is studying innovative concepts, technically reliable, advanced concepts that someday could change "the possible" in the aerospace industry.

Selected in the 2<sup>nd</sup> phase of the NIAC 2015, the HERTS project team received an additional of 500.000USD to submit tests and eventually change not only how NASA is moving to the heliopause but also within our solar system.[2]

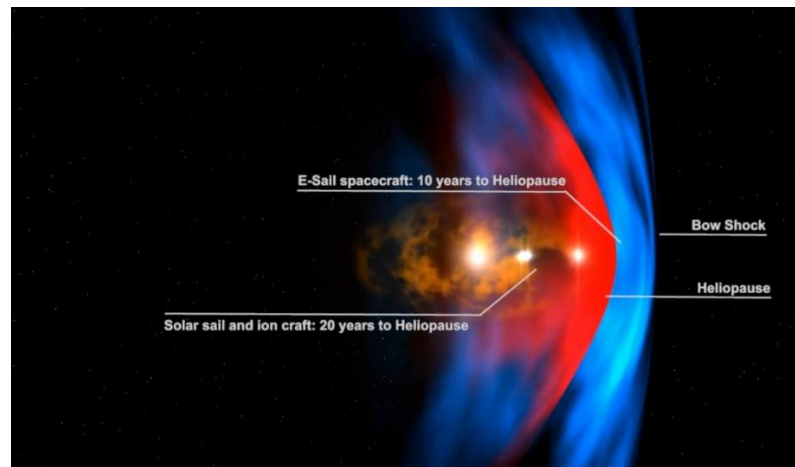

**Fig.5** HERTS system's range (15-20AU) compared to E-sail and Ionic thruster (5AU)

## CONCLUSIONS

My project presented a review of the current innovative methods and concepts of propulsion in space with all the pros and cons. There is also a brief history starting with DaVinci drawings and pioneers of aviation to our current ways of propulsions. It is also presented a comparison between the three innovative concepts that could change the way we travel the space.

In this project, the HERTS system is the most detailed concept because after some research I concluded that it is the most convenient and most efficient way for gaining thrust in interstellar space. The system is credible, technically feasible and well developed theoretically speaking. I hope that one day not too far to watch the successful launch of the HERTS project in the space.

## REFERENCES

- [1] <http://www.da-vinci-inventions.com/flying-machine.aspx>
- [2] <https://www.nasa.gov/centers/marshall/news/news/releases/2016/nasa-begins-testing-of-revolutionary-e-sail-technology.html>
- [3] [https://en.wikipedia.org/wiki/Astronomical\\_unit](https://en.wikipedia.org/wiki/Astronomical_unit)
- [4] [https://en.wikipedia.org/wiki/Spacecraft\\_propulsion](https://en.wikipedia.org/wiki/Spacecraft_propulsion)
- [5] <https://cs.stanford.edu/people/eroberts/courses/ww2/projects/jet-airplanes/planes.html>
- [6] [https://ro.wikipedia.org/wiki/Istoria\\_avia%C8%9Biei](https://ro.wikipedia.org/wiki/Istoria_avia%C8%9Biei)
- [7] <http://sail.planetary.org/>
- [8] [https://ro.wikipedia.org/wiki/Motor\\_cu\\_reac%C8%9Biei](https://ro.wikipedia.org/wiki/Motor_cu_reac%C8%9Biei)

## THE INFLUENCE OF METEOROLOGICAL PHENOMENA ON AVIATION

**Alexandra-Elena BOMBEA**

“Henry Coanda” Air Force Academy, Brasov, Romania (abombea@yahoo.com)

***Abstract:** The aim of this project is to present aviation accidents produced due to bad weather. A group of people contributes to a flight preparation and they are the ones who care for its ongoing in optimal conditions. The meteorologists have an important role by analyzing the evolution of the meteorological phenomena and determined flight conditions. The aviation accidents happen due to the wrong forecast but mostly because of the unpredictable weather. I will present a series of aviation accidents and the phenomena that caused them.*

***Keywords:** aviation, meteorological phenomena, disasters, wind, storms, visibility, turbulence*

### 1.INTRODUCTION

**1.1** The mass of air that surrounds the Earth represents the essential fluid for life, but also for aviation. The atmospheric air ensures lifting for aircraft, combustion processes in engines, flight control effectiveness, engine cooling, passenger cabin pressurization and other facilities without whom flight would be impossible.[1]

But, in addition to utilities offered, the atmosphere also has negative effects, sometimes fatal, on safety of flight. Often, whole areas of airspace are temporarily removed from service for air traffic due to dangerous atmospheric phenomena. It may be said that measures efficiency, to prevent air disasters owing to the weather factors, is almost complete. An international meteorological information system provides access to all those interested in actual data and forecasts on the evolution of atmospheric phenomena on airlines. Staff routing inform flight crews in real time about the dangers of natural phenomena or dangerous routes around airports. Specialized equipment on the ground, combined with the on-board reached such perfection that ensures performance of landings "blind" - near automatic and contact with the runway under total darkness (Ex. - ILS Category III performance). All these measures should exclude the virtually risk of air accidents due to the environment, but exceptions remain. [1].

The most common causes of aviation accidents are the mistakes pilots (in 53% of cases), mechanical failure (20%), bad weather (11%), sabotage and bombs, kidnappings or fell ing intentioned (8%), other human errors - improper load, communication errors, improper maintenance, etc. (7%), 1% other causes.[4]

#### **1.2 Aviation disasters caused by weather conditions**

Adverse weather conditions are the cause of about 10% of the air disasters. Despite the fact that modern aircrafts are equipped with electronic aids for safer navigation, such as compasses, gyroscopic systems, satellite navigation, and feature data on weather, aircraft still faces the threat of storms, snow or fog.[3]

All weather events can affect aviation but some of them can produce aviation accidents casualty and property damage, for example: turbulence, wind, storms, visibility, frost, frost, thunderstorms (lightning), glazed frost, ice, etc.

## 2. ACCIDENTS CAUSED BY TURBULENCE EFFECTS

Turbulence occurs when air currents are deflected or when two masses of currents collide at directions and different speeds. The most common cause of turbulence formation is the presence of convection currents - they are sun-heated air masses that form in clouds and planes traversing these portions encounter turbulence. [6]

According to the pilots, turbulence are caused by air currents, and these currents interacting with the aircraft. They occur even when unusual weather conditions do not exist, the sky is clear and the wind does not blow hard.

Acting on aircraft under flight movements out of balance turbulent aerodynamic forces and moments, a situation that causes changing the angle of attack and thus increases or decreases in successive laps, lift dumpers. This presents vertical accelerations and therefore, inertial forces that tend to balance the difference between portable and airplane weight (overload).

Experienced pilots understand the causes of turbulence and know all the ways that you can avoid them. For example, some of these phenomena can be repeated many times during a flight and very often throughout the day. Different intensity, they are successfully avoided or overcome without problems. No matter how unpleasant, they do not generate air accidents. [5]

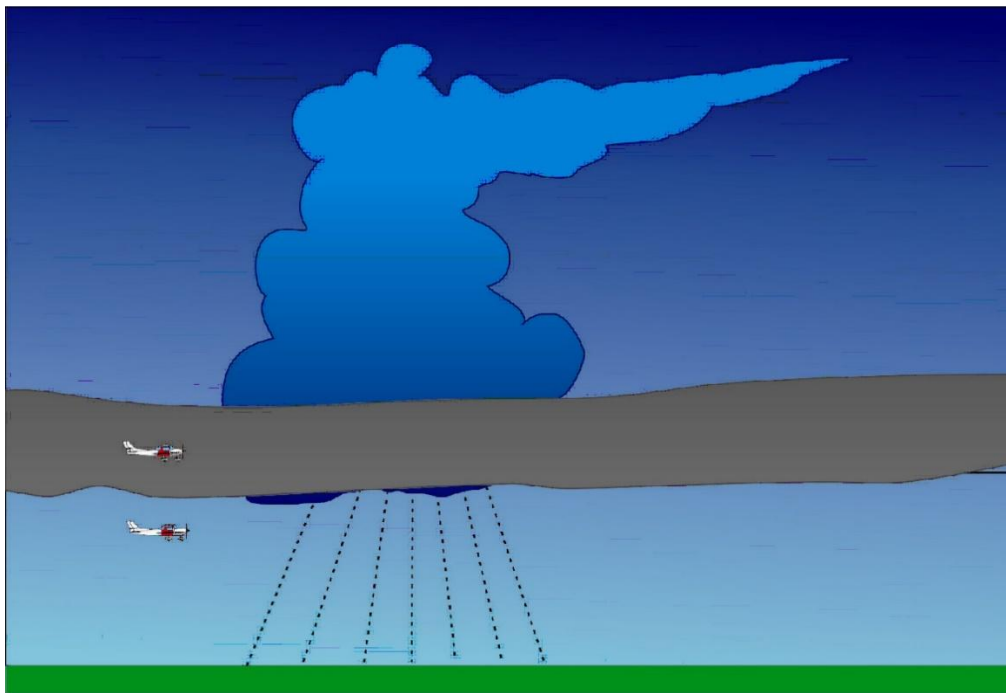

FIG.1[9]

An exception is made following the accident:

In the afternoon of January 10, 1952 at Northolt Airport (United Kingdom) [...] flight destination Dublin (Ireland), a DC-3 airplane Company "Air Lingus", took off at 5:25 p.m. with 20 passengers on board and 3 crewmembers. Although it was a day that bears the mark of a period of harsh winter, nothing gives the impression that the flight would not normally arise, however, in full safety. The aircraft enrolled quickly by air and fly by the instruments at night in clouds at an altitude of 1500 m, set in the flight plan. After about an hour and a half, the aircraft commander sought permission to climb another 700 m, without reasons for his request. [1]



He arrived at that altitude after a quarter of an hour when he reported by radio and in the next few minutes, the plane has not responded to calls of the control tower.

Entering an area with intense turbulence, the ascending-descending currents, strong headwinds pushed the plane in the Welsh Mountains. The aircraft commander realized that they are not above the Irish Sea, where it should be, and that was deviated by more than 30 kilometers from the route, reaching the valley of Snowdon, where natural phenomena broke the plane into the air. [1]

### **3. ACCIDENTS CAUSED BY POOR VISIBILITY**

Along with cloud cover (cloud coverage), visibility is a very important meteorological element for air navigation, aerial firing and bombing, aerial photography, taking off and landing aircraft.

Visibility is defined as the greatest distance to an object or landmark can be found and identified.

An example of an accident caused by poor visibility but also wrong meteorological information was Viscount plane crash, in London, on 7 January 1960. Although visibility was very bad and dense fog covered the airport, the plane was authorized by traffic controller to land. The pilot saw the runway at the last moment, when the plane was descending. The landing was very hard on the front wheel, which resolved immediately. The aircraft slid few hundred meters above the hull in direct contact with the track, which generate a serious fire. The 59 persons on board - passengers and crew - had a great chance to escape death, due to the professionalism of the crew, who managed to organize a rapid evacuation. [1]

### **4. ACCIDENTS CAUSED BY WIND**

Wind is one of the most important meteorological elements exercise a great influence on the flight of aircraft, both near the surface and in altitude.

Wind ground directly influences takeoff and landing of airplanes and helicopters.

The wind in altitude affects their navigation through both its components: direction and speed.

Typically, planes taking off and landing runs against the wind, which lowers speeds and distances required to peel off the runway and, respectively, for landing.

If sailors they wish each other the wind stern meaning behind the ship for pilots such wind in moments of takeoff or landing can become very dangerous, because it reduces the relative speed of the aircraft to the environment and therefore buoyancy that keeps aircraft in flight. Before take off, the pilots informed on speed, direction and wind direction at the airport, and directs traffic enforcement aircraft to take off with the wind in front of the aircraft. So did North American pilot of the plane B-727, on 3 July 1977 Airport Tucson (USA). He was steered off to the southwest, and the wind was blowing from the south about 20 kilometers per hour. The airport tower controller advised him of the possibility of rapidly changing wind direction and intensity. A few minutes earlier, a gust of 80 mph was recorded during a strong wind. Unfortunately, it has happened as the controller estimated. Exactly during takeoff, the wind changed direction and meaning, blowing hemisphere back of the plane, which aggravate decisive take off maneuvers. [1]

The plane took off hard although engines were at full power and hit a network of highly voltage courts 250 m from the runway end. The pilot managed to control the airplane and people discharged because he had major damage and at any moment could catch fire.

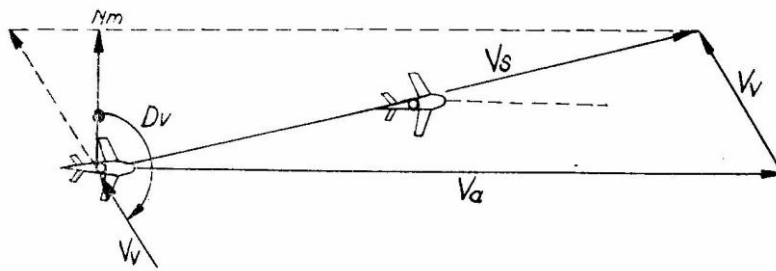

Influența vântului asupra zborului avionului

FIG.2[11]

## 5. ACCIDENTS CAUSED BY STORMS

Very strong wind, relatively long duration, which usually occurs when passing deep cyclone is accompanied by destructive effects on land and a strong agitation of the waters. [7]

Hail to the size of the granules can cause considerable damage to aircraft both in flight and on the ground: and the fuselage structure deflection plans, breaking the dome cabin and headlight cluster, tearing external antennas. In flight, the damage caused by hail to the aircraft is directly proportional to the speed of flight.

For example, within the two polar circles – Arctic and Antarctic – almost all storms in warm seasons are accompanied by hail. The phenomena occurring on board radar screen in the form of bright cores that invites caution and obviously changing flight route. They are carefully tracked by ground weather stations and specialty warnings by traffic authorities, for crews in flight or in preparation for takeoff. On 19 July 1979 at six minutes after takeoff, the plane DC-8 Company "Japan Airlines" with 98 persons on board, met a strong hail, signaled last moment on the radar screen as a core of the storm, impossible to avoid. The bombardment of ice particles whose kinetic energy is always magnified speed flight-bean composition, brought the plane to limit the catastrophe. Central windshield was broken, radar stations antennas for radio navigation and destroyed, wings, bonnets and air intakes deformed engines and speed indicators out of service. [1] Because the master and crew mastery plane landed safely and there was no death.

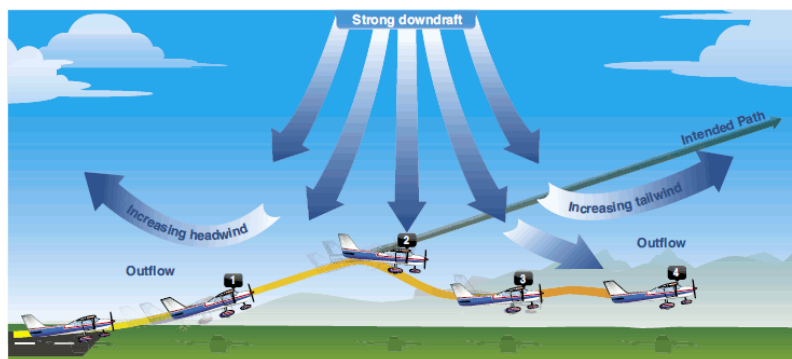

FIG.3[10]

## 6. ACCIDENTS CAUSED BY LIGHTNING

Lightning is a luminous phenomenon that occurs with sudden discharge of atmospheric electricity. The electrical discharge can take place in the clouds or it could leave the cloud.

The thunder is a thud that accompanies lightning. If electric discharge occurred close of observer violent thunder, the noise first short, then a final crack. If discharges are away, rattling thunder sounds like a dull and protracted. The lightning always appears first, then men can hear the thunder owing to the difference between the speed of propagation of the light and the one of the sound. [8]

For example, the winter of 1951 in the Northern Hemisphere has been warmer than usual so thunderstorm phenomena frequently climbed up to the middle latitudes. On January 17, a flight from Paris to Rome Savoia Marchetti aircraft commander did not expect to have some thunderstorm phenomena on route. After 4 hours and 20 minutes of flight without difficulty plane crashed into a field with great thunder and lightning struck fuel reservoir. The plane was turned into a torch and survived only two passengers and a crew member.

By contrast with the accident in December 1963 none of the 73 passengers and eight crew members survived. Boeing-707 of "Pan American" company linking Baltimore (USA) with the Caribbean island of Puerto Rico took off from Frienschip and, after passing the Delavare beacon, entered into an area that was haunted that night by a storm accompanied by hail and lightning. The commander of the aircraft using information primates managed to exit of the area but could not avoid electrical discharges. Thus, shooting lightning pierced the plane caught fire and crashed in fire.[1]

## 7. ACCIDENTS CAUSED BY ICING

Icing involves placing a layer of ice on aerodynamic profiles of the aircraft during flight in the clouds or in the clouds, and in areas with precipitation (rain, snow) or fog, especially at temperatures between 0 and 10 degrees C.

Icing considerably worsens the aerodynamic qualities and flight characteristics of aircraft, which affects the technique and purpose of the flight deck. Its effects are reflected in changing the wing profile, increase drag, decrease buoyancy, increase the mass of the airplane, increasing traction and decreasing traction necessary surplus.

If the aircraft is on the ground and icing is signaled icing operations are carried out using special heaters and liquids.

An example is the icing accident caused on the 2<sup>nd</sup> January 1949 when, after the New Year's Eve in Seattle (USA), 19 passengers and three crew members embarked aboard a DC-3 airplane. Fog delayed the departure of the present airport and the waiting period was fatal. An ice layer was deposited on the fuselage, wings and empennages aircraft that became unusable for several hours. It was attempting to remove ice but the operation was incomplete.

The commander decision to take off signed their death conviction. It reached in the direction of take-off motors in full, the plane began turnover for takeoff, but after the first 600 meters, came off the ground, leaned on the left wing and became uncontrollable and hit a shed and then caught fire and burned complete. Only 8 passengers could be rescued from this accident which was based icing.

## CONCLUSIONS

In aviation, at every flight pilot is the one who is holding his own life and many other people's, both passengers and the aviation personnel. Disasters are caused by many factors and an important one is represented by the weather phenomena.

It should be considered that weather phenomena that occur in nature can not be controlled by humans but can be predicted and anticipated the way, place and time of the event. Meteorologists try to "predict" what will happen at a given time in a given area. Based on measurements and information received from the meteorological station is provided a forecast showing weather situations over a period of time. If the medium term (months) and short (days) weather forecasting has a high chance of success, very short-term (hours) weather type *nowcasting* must face challenges far more complex, dynamic spatial and temporal very fast which makes it more difficult to anticipate the evolution of phenomena. Improving *nowcasting* forecast type is essential for aeronautical activity to avoid air accidents caused by weather.

## REFERENCES

- [1] Adrian CRISTEA, Andrei Cristea, editura Axioma Print ,București 2009- *Marile catastrofe aviatice ale secolului XX* .
- [2] *Air Law & Meteorology* , Volume 2- CAA Recommended, EASA Part-FCL Syllabus Compliant, LAPL Syllabus Compliant, National PPL Syllabus Compliant, Includes Question & Answer Section, Published by Pooleys-Air Pilot Publishing Ltd, England 2014 (Twelfth edition May )
- [3]\*\*<http://www.stiintaonline.ro/principalele-cauze-ale-dezastrelor-aviatice/>, accessed on: 21.02.2017
- [4]\*\*<http://www.hotnews.ro/stiri-arhiva-1115235-accidentele-aviatice-inspaimanta-dar-avionul-ramane-cel-mai-sigur-mijloc-transport.htm>, accessed on: 21.02.2017
- [5]\*\*<https://www.eximtur.ro/Informatii-despre-bilete-de-avion/Care-sunt-cauzele-si-cat-de-periculoase-sunt-turbulentele--eID624.html>, accessed on: 21.02.2017
- [6]\*\*<https://www.esky.ro/ghid-de-calatorie/bilete-de-avion/intrebari-frecvente-bilete-de-avion/ce-sunt-turbulentele>, accessed on: 21.03.2017
- [7] <http://meteorologie.ro/modules.php?name=Encyclopedia&op=content&tid=128>, accessed on 7.03.2017
- [8]\*\*<http://ruxache.ro/la-pas-de-stiut-prin-munti/definitii-fenomene-meteo.html/>, accessed on: 7.03.2017
- [9]\*\*[https://www.google.co.in/search?q=influenta+vizibilitatii+asupra+aviatiei&source=lnms&tbm=isch&sa=X&ved=0ahUKEwjs2rDB6erSAhXBvBQKHUPUCFUQ\\_AUIBigB&biw=1366&bih=662#tbm=isch&q=influenta+givrului+asupra+zborurilor\\*&imgcr=G3txNzRMrpvxmM:](https://www.google.co.in/search?q=influenta+vizibilitatii+asupra+aviatiei&source=lnms&tbm=isch&sa=X&ved=0ahUKEwjs2rDB6erSAhXBvBQKHUPUCFUQ_AUIBigB&biw=1366&bih=662#tbm=isch&q=influenta+givrului+asupra+zborurilor*&imgcr=G3txNzRMrpvxmM:), accessed on: 22.03.2017
- [10]\*\*[https://www.google.co.in/search?q=influenta+vizibilitatii+asupra+aviatiei&source=lnms&tbm=isch&sa=X&ved=0ahUKEwjs2rDB6erSAhXBvBQKHUPUCFUQ\\_AUIBigB&biw=1366&bih=662#tbm=isch&q=influenta+givrului+asupra+zborurilor\\*&imgdii=ZYhqw6qHzsflM:&imgcr=VKrilmqsy19vM:](https://www.google.co.in/search?q=influenta+vizibilitatii+asupra+aviatiei&source=lnms&tbm=isch&sa=X&ved=0ahUKEwjs2rDB6erSAhXBvBQKHUPUCFUQ_AUIBigB&biw=1366&bih=662#tbm=isch&q=influenta+givrului+asupra+zborurilor*&imgdii=ZYhqw6qHzsflM:&imgcr=VKrilmqsy19vM:), accessed on: 22.03.2017
- [11]Manual de aviație aeriană, București 1987, ediția aIIa, Republica socialistă română Mapn, Comandamentul aviației militare.

## OPTIMISM VERSUS PESSIMISM IN LEADERSHIP

Carmen-Elena BARANIUC

"Henri Coanda" Air Force Academy, Brasov, Romania

**Abstract:** *The following paper aims to present the psychological profile of leader, what leadership represents and in which way these aspects affect interpersonal relationships and work performance. Moreover, details regarded the influence personality traits, leadership activity and leadership styles have on the social evolution of a true leader are included. The focus lies on the attitude towards life that leaders approach and the way optimism or pessimism manifest along their activity.*

**Keywords:** *leadership, behavior, optimism, pessimism, relationships*

**Motto** "Leaders have some needful qualities of contagious trust, limitless optimism and incurable idealism which allows them to engage and mobilize others in order to fulfill tasks which they have not even dream to become reality" (Tom Cronin, 2011: 405)

### 1. INTRODUCTION

Human activity is a continuous learning, adaptive and competitive process. This aspect is visible in all areas of activity in which the aim is towards survival and improvement. In fast growth of competition on an unprecedented level, the role of managers and exclusively leaders grows in importance. They are the ones expected to create, to improve and bring to life their vision of success, which by the strategies and politics approached will lead to evolution. The semantics of the terms manager and leader differ, although on a practical level the two notions are meant to be synonymous. While the manager holds a position of influence which results from his formal place in the hierarchy of the organization, the leader wins sympathy and influence through the qualities he possesses and cultivates in interpersonal relationships.

The conceptual borders of the two different notions have been settled by specialized literature. On a first analyzes, the two notions are to be used in a certain context without the specific intent to differentiate one from the other. The second situation lies in opposition with the latter, by strictly emphasizing the difference between management and leadership, viewed as practically antagonistic. The idea resulting from this experiment is that management is naturally associated with the cognitive, imaginative plan while leadership is associated with dynamism, vitality impetus. The leader is a penetrating spirit, with multilateral possibilities of thinking, psychological activities, who thoroughly analyzes and decides the action plan, while the manager only applies the leader's idea, - only the operational activities (savoir faire). Leadership represents the human dimension, the level of dedication and training in the activity, while management – the executive part of the process.

## 2. WHAT IS LEADERSHIP?

**“To be a leader means to manifest excellence in every aspect of your life” (Peter Koestenbaum, 2011: 408)**

There is no domain of life and social practice that is indifferent the vast, current problematic of leading. Industrial, educational, political, military, administrative, banking, commercial, sportive etc. organizations make constant efforts to the improvement and perfection of leadership. Leadership is of great significance for the present as much as it is for the future, it is one of the main management – oriented fields that has been researched over the most. Thus, the definitions of leadership vary by the object referred to and by the meaning that is given to it in a certain situation. Leadership represents a dynamic process – that influences the activity of a person towards reaching the aims of an organization. Moreover, leadership teaches the art of keeping the members of a group grounded in their will to benefit the organization in a way that grows their respect, trust and cooperation with all their heart. The essence of leadership lies in the metamorphosis of a vision in a possible reality, which involves the ability to reach its goals through the work and actions of those who are in the position of power guidance is a solid ingredient in leadership. Leaders rule not by giving directions, but through persuasion, motivation and empowerment of the subordinates. They identify and gain involvement on behalf of their men. Also, they do not manage only individual performances, but the group’s output, by creating a favorable organizational environment. When it comes to leaders, certain criteria are identified by which they separate from managers: the manifestation of personal attitudes, active by creativity originality and the ability to anticipate the possible outcomes. Their outlook on work is based on creating new opportunities, communication and the inclination towards change, and in the interpersonal relationships they possess empathy, give much credit to cooperation and awaken trust in others. A leader has the ability to make people be pleased with their job and helps them feel that their work contributed to the final aim of the organization. This encourages subordinates to surpass the basic level of efficiency and try to reach out for their full potential by recognizing their achievements and success.

**2.1 Leadership types.** In essence, dividing several types of leadership depends on the efficient use of human resources in today’s society. Leaders receive influences form diverse sources, the most important of which are correlated with the leader’s personality and the context in which he evolves.

*Charismatic leadership* represents an actual type (and a superior one) of ruling. It is found in people that possess charisma, a construct of special qualities, personal charm – who leave a native talent of profoundly influencing the people they come in contact with. Given that native qualities are polished through education, experience, the leader becomes a prominent personality wherever he places his activity. Charisma leaders are known for the incredible reliance in their own strength, values and their ability to hunt down whatever they pursue. Thus, a psychological attraction evolves between the subordinates and such magnetic presence.

There is no denial that leadership represents a complex relationship between the leader and subordinates, where the interpersonal contact is of high value. Practically, not only leaders influence subordinates but the reverse is also valid.

*Transformational leadership* describes a person that is genuinely capable of awakening in others the need and will to achieve extraordinary performances. This trait characterizes the leaders who sense the inclination towards progress, the ones that give credit to the individual improvement of their followers. Transformational leaders enlarge and fuel the personal interests of their subordinates, but motivating them to exceed the personal level. Still, transformational leadership differs from transactional ruling, in a way that the latter is more systematic in maintain the subordinates focus on reaching objectives. Transformational leadership produces levels of effort and performance highly superior to the possible results of transactional approach. The true transformational leaders, offers a powerful aura to his vision and enthusiasm, which substantially levels up the trust, involvement and interest of people to contribute to the organization.

**2.2 Leadership styles.** Combining the proper training of subordinates with two dimensions – orientation towards settled chores and the focus on interpersonal contact – four specific leadership styles ensue: directive, persuasive, participative and delegating.

*The directive style*, suited for a poor training lever, relies on autocratic ruling, based on power as well as limited supportive social relationships. It is used best when immediate action is needed.

*The persuasive style* is prolific for subordinates who fall in a low to moderate training category and it fancies manipulation and sustained guidance. It is directive by nature, but emphasized on the “hows” to complete a task.

*The participative style* corresponds best to an average to high level if training on behalf of the subordinated. It involves intense communication and focus on social relationship, with a reduced guidance in achieving a certain goal. It is regarded as democratic style as it allows subordinates to organize and plan their next step individually.

*The delegating style* matches the situation in which subordinates are thoroughly trained and do not request guidance or encouraging through interpersonal contact: the “laissez-faire” style.

### 3. THE PSYCHOLOGICAL PROFILE OF THE IDEAL LEADER

**“A leader needs to search for people with a winning attitude, positive and passionate for what they do” (Rick Pitino, Bill Reynolds, 2011: 407)**

The definite distinction between important factors which contribute to effective leadership is a necessary condition for the selection of managers who will occupy leading positions in an organization. Anyone who aspires at a successful career in leadership must tend to meet the psychological request of an ideal leader, who brings leadership in the area of social influence phenomena.

From the social psychology perspective, leadership is nonexistent in the absence of definite interpersonal relationships. To lead means, among other, to work with people, to constantly relate to their lives, interest, aspirations, both personal and individual. Thus, the primary resource of leadership is the human resource, as in a group there may not be one single leader, but several prominent figures who personify an inspirational beacon and their contribution resembles the one of multiple leaders.

Leadership arises at a three path junction: *leader-subordinates-situation*. There is a theory that states the success of leadership exists due to a series of qualities, capabilities and personality traits specific to the one in the ruling position, details which assure no authority and success in his demeanors. By correlating leadership with the psychological dimension of the ideal leader, a series of factors are present in both: certain qualities (vision, attention, courage, competence); capacities (intelligence, communication, originality); the attitude of a winner (instruction, knowledge, power), responsibility (safety, perseverance, trust); involvement (sociability, adaptability, humor).

#### **4. OPTIMISM VERSUS PESSIMISM IN LEADERSHIP**

Leadership relies on a series of qualities or features which separate those gifted to become true leader from the masses. Man displays through his personality initially shaped by educational attitudes regarding life which represent individualized aspects of behavior and psychic structure, attitudes which lead to a certain level of adaptability to the environment in a given situation. As review upon life and human condition, optimism rises to affirm the complete accomplishment of a leader, the improvement of social progress, as the moral disposition to look at life with faith in the future. On the opposite end of the scale there lies pessimism, a set of beliefs that priorities evil over good, the predisposition to view life governed by hopelessness and the inability to trust fellow human beings. In a psychological way, the two life conceptions reflect in the leadership style of the ruler, who influences and is being influenced by his subordinates.

The specific ruling style of each leader conveys temperamental traits which find their expression in behavior and personal conduct, bringing an advantage to the leader. While temper traits are innate, the leader is difficult to shape by the standard criteria approached by leadership; thus, their selection is preferably made on other psychological foundations, too. "The temperament favors the personality, but it does not confer values" (Paul-Popescu Neveanu, 2011: 32)

Encompassed in a specific leadership style are several individual aptitudes – usually the psychosocial ones, aptitudes that are formed and evolve during the entire lifespan of an individual. Aptitudes are features that differentiate individuals from one another by the manner of managing certain situation and by the field they obtain at the end of a workday. "The aptitude consists in the natural and acquired disposal to perform certain tasks" (Norbert Sillamy, 2011: 53). An important aspect is the difference between aptitude, which is a potential trait, and capacity, which is the consolidation of a trait by practice. Character as a rational value-related dimension is a moral standard based on the strength of inner convictions and the power with which they are affirmed and persist in time. Byll Hybels defines character as "What we are then nobody sees us"; as what is done in private, when social restrains one at a minimum, reflects true character and integrity.



It is to be understood that a radical change in personality traits is not necessarily needed to obtain a change in the leadership style, but rather a reorganization and balance of the already existing traits, or merely are emphasis on the positive ones is recommended.

The sum of character traits polish a common-sense based personality, dominant and practical, of a leader who trusts his strength, his people and his goals. Optimism and pessimism as philosophies and attitudes towards life, influence the overall performance of leadership. Optimist leaders are open hearted, warm and magnetic and access their full potential easily in interpersonal relationships, by persuading with ease the subordinates to turn into his own state of heart and strengthen the cohesion of the group.

From a psychosocial perspective, an optimist leader concentrates his attention equally towards a given task and interpersonal contact, which makes him efficient and determined. As an extrovert spirit, he stimulates the social interaction between his position and any other position in the group he manages, favoring freedom of speech and feeling implication and decision-making. On the other hand, in general, a pessimist leader shows no success with a group. Repulsive attitude and negative thinking narrows subordinates perspectives and forces the latters to meet opportunity with doubt and resent.

## 5. FINAL CONCLUSION

Leadership is at its core an accumulation of features as vision, integrity, intelligence, competence, responsibility, empathy, as well as a powerful personality. A true leader flourishes due his innate abilities, but he must find himself in a constant pursuit to improve the relationship with his subordinates. Its portrait is covered in optimist, producing the expected positive outcome, and his soul lies in the art of working with people, relating on a deeper lever.

### STUDY ON THE LEVEL OF OPTIMISM AND PESIMISM IN THE MILITARY ENVIRONMENT

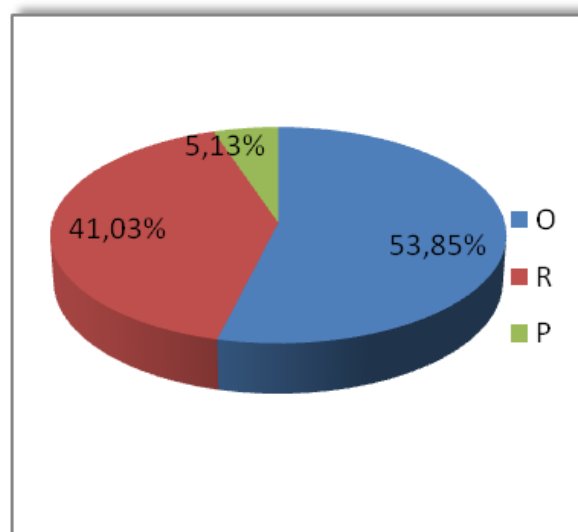

**FIG. 1:** Military student's attitude towards life expressed by optimism (O), realism (R) and pessimism (P)

53,85% of the subjects (second year students, military branches: ATC, NFP, EW and RO) manifest an optimistic attitude towards life. This is explained through an inner balance condition and a confident conviction in the joy of life, accepting at the same time the ups and downs. On the second place are ranked the realistic ones in proportion of 41,03% in opposition with the previous category. Realistic students understand life as a succession of ups and downs. Therefore they are more pressured by worries than them.

Ranked third are the pessimists (5,13%) which have a negative, non-productive attitude and also the tendency to exaggerate the existential dangers and to create a defensive barrier against the challenges of the future.

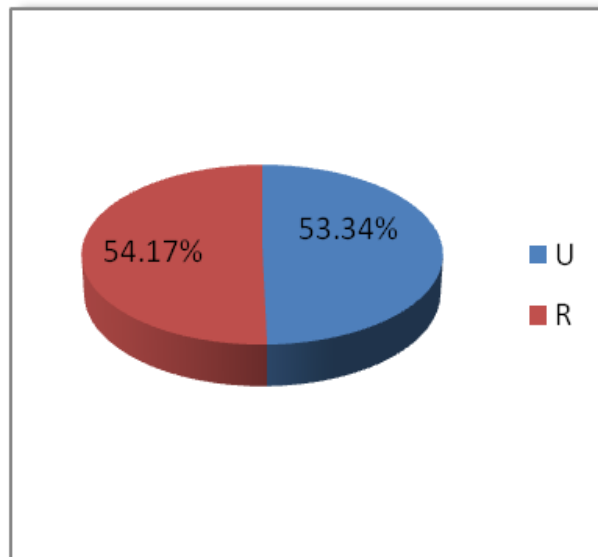

**FIG.2:** Level of optimism depending on the environmental origin: Urban (U) - Rural (R)

The optimistic students are found in both categories almost equally based on the correlation between attitude towards life and environmental origins. But those coming from the urban area are more optimistic. This little difference is caused by the current condition of the Romanian villages, an aging population with lack of jobs and with the intensified agriculture crisis.

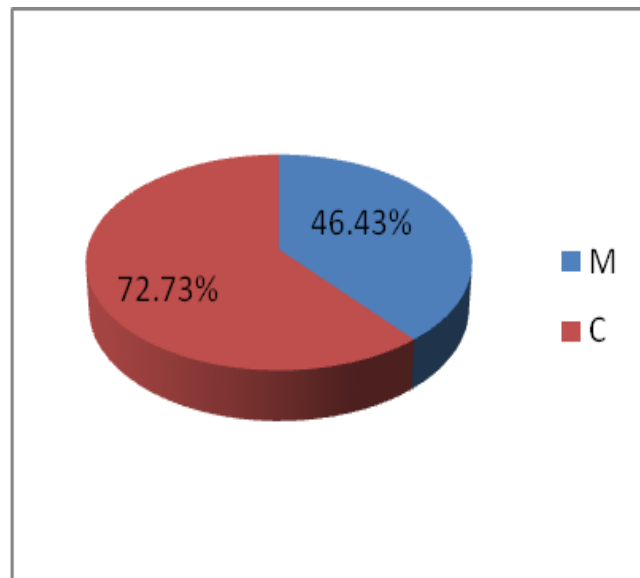

**FIG.3:** Level of optimism depending on the graduated high school: Military (M) – Civil (C)

This processing data highlights that the graduated high school has a massive impact on the teenager's attitude towards life. The optimistic attitude of the civil high school graduates prevails in proportion of 72,73% despite the military ones (46,43%). This might be due to secondary socialization of the teenagers in the military environment, saturated with rules, constrains and many privations. All these characteristics of the military side disagree with age-specific psychological profile and may increase adolescence crisis. The consequence is the reduction of the level of optimism and openness to the future.

This investigation aims to prepare a more laborious study on the importance of attitude towards life and its impact on leaders and their subordinates' efficiency. This study will try to validate the hypothesis that an optimistic leader has optimistic subordinates and this aspect has a significant impact on the level of the performance of the group.

## 6. REFERENCES

- [1] Gh. Arădăvoaice, *Mentalitatea învingătorului. Profilul psihosocial al omului de succes*, Antet XX Press, București, 2007;
- [2] G. Berger, *Tratat practic de cunoaștere a omului*, Editura IRI, București, 1997;
- [3] R. Heifetz, A. Grashow and M. Linsky, *Leadership adaptiv. De la soluții tehnice la schimbări adaptive*, manual de practică, BMI, București, 2012
- [4] M. Kets de Vries, *Leadership. Arta și măiestria de a conduce. De la paradigma clinică la pragmatismul schimbării*, Codecs, București, 2003;
- [5] Dr. C-tin Moștoflei and Dr. P. Duțu, *Liderul militar în România*, Universității Naționale de Apărare „Carol I”, București, 2007;
- [6] V. Roman, *Liderul militar performant. De la talent la educație*, Centrului Tehnic Editorial al armatei, București, 2013;
- [7] Bertrand Russell, *Credințele mele*, Humanitas, București, 2014
- [8] Dean Williams, *Leadership Real. Oameni și organizații față în față cu marile lor provocări*, Codecs, București, 2007;
- [9] P. Popescu-Neveanu, *Dicționar de psihologie*, Albatros, București, 1987;
- [10] Filozofia de la A la Z. *Dicționar enciclopedic de filozofie*.

## **GAS TURBINE ENGINE COMPRESSORS**

**Patricia-Marina PAUN**

"Henri Coandă" Air Force Academy, Brasov, Romania (ppaun95@gmail.com)

***Abstract:** This article provides a general perspective referring to the characteristics of gas turbine engine compressors. The first part provides a short introduction relating the role of compressors. The second part focuses upon the general principles of functioning. The third part deals with the eventually malfunctions and their causes. The last part refers to the basic methods of construction commonly used in compressor assembly.*

***Keywords:** centrifugal and axial compressors, blade, compressor stall, surge line.*

### **1. INTRODUCTION**

The air must be compressed before having fuel added to it in the combustion chambers and subsequent expansion in the turbines. There are basically two types of compressor in use in engines presently available, one allows axial airflow through the engine while the other creates centrifugal flow. In both cases the compressors are driven by a turbine which is coupled to it by a shaft. There are several different types of jet engines, but all jet engines have some parts in common. All jet engines have a compressor to increase the pressure of the incoming air before it enters the burner. Compressor performance has a large influence on total engine performance.

There are two main types of compressors used in modern jet engines: axial compressors, and centrifugal compressors.

The centrifugal compressor is much more robust than the axial flow compressor. That and the fact that it is the easiest and cheapest of the two types to manufacture made it a popular choice in early gas turbine engines. It does however have one or two disadvantages which have relegated it to the second position in term of large modern engines. If we compare two compressors with the same frontal area, one centrifugal and other axial, we would first of all find that the axial flow compressor can consume far more air than the centrifugal compressor and secondly that much higher compression ratios can be attained in the axial flow compressor. Since the amount of thrust generated by an engine depends partly upon the mass of air flowing through it, it can be demonstrated that the centrifugal compressor engine will have less thrust than an axial flow compressor with the same frontal area.

### **2. THE PRINCIPLES OF THE COMPRESSORS**

The action of the turbine rotates the impeller of the compressor at high speed. Air is introduced continuously into the eye, which means centre, of the impeller by rotating guide vanes and centrifugal force causes it to flow outwards towards the tip. Because of the divergent shape of the vanes the pressure of the air increases as it flows outwards, and because we are adding energy into the equation, the air's velocity also increases. The air leaves the tip of the impeller and passes into the diffuser section, a system of stationary divergent ducts designed to convert the kinetic energy into potential energy.

In practice approximately 50% of the pressure rise across the compressor occurs in the impeller and the other 50% in the diffuser section. The compression ratio of a single stage centrifugal compressor would be in the region of 4:1. That means that the outlet pressure of the compressor stage would be approximately four times greater than the inlet pressure. To attain greater engine compression ratios using centrifugal compressors two of them would have to be used in series with each other. In practice it has not been found feasible to use more than two centrifugal compressor stages together, excessive impeller tip speeds and extreme centrifugal loading prohibit efficient operation of a third stage. As a result of this, engine compression ratios of greater than 15:1 are not considered possible using centrifugal compressors. At the elbows of the compressor outlet casing cascade vanes are fitted. These enable the air to be turned through large angles with the minimum of loss, and they are also used to complete diffusion.

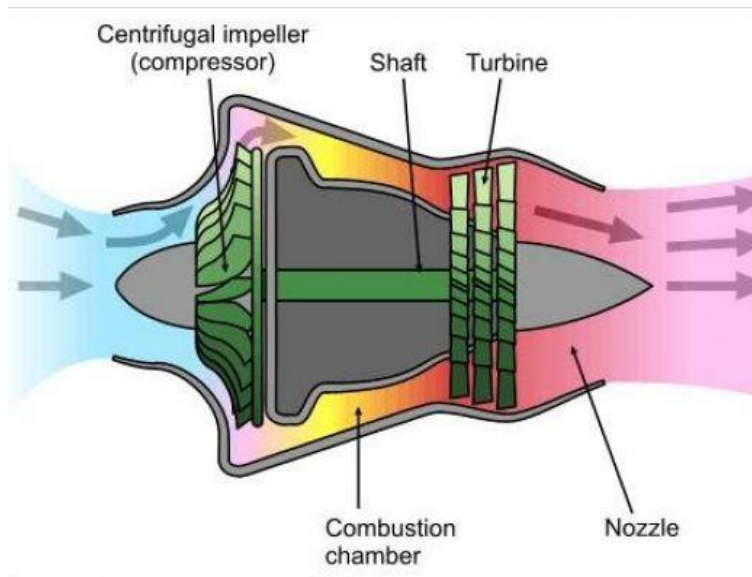

**FIG. 1.** The centrifugal compressor

The principle of the axial flow compressor is basically the same as that of the centrifugal flow compressor, it converts kinetic energy into potential energy. The means which it uses to achieve this conversion are however different. The axial flow compressor, consists of several rows of rotating blades of aerofoil section interspersed with rows of stationary diffuser blades, also of aerofoil section. A stage consists of one row of rotor blades, fastened to discs on a rotor drum, followed by a row of stator blades, which are fastened to the compressor outer casing. On both the rotor and the stator the spaces between the blades form divergent passages. In the rotor, which is turned continuously at high speed by the turbine, mechanical energy is added and converted into both kinetic energy and potential energy. Within the stator, the pressure is increased by the conversion of the kinetic energy into pressure energy. Simply stated, the rotor stages can be seen as doing the same job as the impeller in a centrifugal compressor, while the stator stages can be compared to the diffuser in a centrifugal compressor. The pressure rise across each stage is only quite small, the ratio being about 1.1 or 1.2:1. This means that in the first stage the pressure might only increase by about 3 psi. As a consequence of this, in order to gain the compression ratios demanded by modern engines, many stages may be used on the same spool, and an engine may have up to three spools. So effective is this method of compression that in an engine like the RB 211 compression ratios as great as 35:1 can be attained. In this engine, the pressure rise over the last stage can be as much as 80 psi. These high pressures can result in compressor outlet temperatures of up to 600°C. Some engines now use a combination of centrifugal and axial compressors.

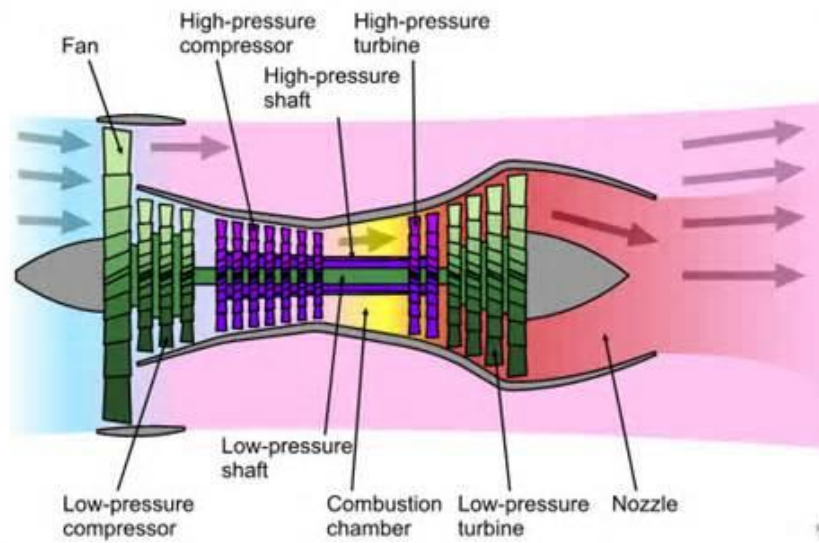

FIG. 2. The axial compressor

### 3. AIRFLOW CONTROL

Increasing the compression ratio of a compressor makes it progressively more difficult to ensure that it operates efficiently over the whole of its speed range. This is caused by the fact that the compression ratio of the engine falls as the speed of rotation of the compressor falls. Therefore, as the engine slows down, the volume which the air takes up gets greater and greater, because it is not being compressed so much. The increased volume of air at the high pressure end of the compressor makes it difficult for it to pass through the space available and so it slows down and in some cases can cause choking and turbulence. This reduction in axial velocity happens throughout the compressor and can cause a phenomenon called stall, which if not checked can progressively worsen to produce surge, a situation where, in the worst case, the airflow through the engine can instantaneously reverse its direction of flow.

The angle of attack of a compressor blade is the result of the axial velocity of the air passing across it and the rotational speed of the blade. These two velocities combine to form a vector which gives the actual angle of attack of the airflow over the blade. A compressor stall can be described as an imbalance between these two velocities which can occur through various causes, some of which are as follows:

- a) Excessive fuel flow caused by abrupt engine acceleration (the axial velocity is reduced by increasing combustion chamber back pressure).
- b) Engine operation above or below the engine design rpm parameters (increases or decreases the rotational speed of the compressor blade).
- c) Turbulent or disrupted airflow to the engine intake (the axial velocity is reduced).
- d) Contaminated or damaged compressor components (decreased axial velocity because of decreased compression ratio).
- e) Contaminated or damaged turbine (loss of power to the compressor causing decreased axial velocity because of decreased compression ratio).
- f) Excessively lean fuel/air mixture caused by abrupt engine deceleration (the axial velocity is increased by the decreasing combustion chamber back pressure).

Any of the above conditions can cause compressor stall to commence, and as soon as it does there is a partial breakdown of airflow through the engine.

The indications of compressor stall are an increase in the vibration level of the engine and an increase in the Exhaust Gas Temperature (EGT). This latter effect (the increase in EGT) is caused by the fact that there is less air going to the combustion chambers, hence there is less air to cool the products of combustion, the exhaust gases. Compressor stall is than a progressive phenomenon, it could initially in theory occur at just one blade, worsening to encompass the whole of one stage, and then, if nothing is done to prevent it, affect the whole engine.

The progressive deterioration of the situation will eventually cause complete breakdown of airflow through the engine called a surge. In severe cases this could cause an instantaneous reversal of gases in the engine, with air being expelled through the engine intake with a loud bang. If surge does occur, the throttle of the affected engine must be closed slowly. The situation is most commonly caused by fuel system malfunction or mishandling and in extreme cases could inflict such large bending stresses on the compressor rotor blades that they contact the stator blades with potentially catastrophic results. Apart from the loud noise that usually accompanies a surge, there is a large rise in the EGT and the resulting loss of thrust may cause the aircraft to yaw.

Operation of the engine outside the optimum rpm and axial velocity range is inevitable, design criteria are, after all, aimed at producing the greatest efficiency near maximum rpm, and operation at levels below that point has to occur if we are to be able to throttle the engine back. This means that we are committed to altering the rotational speed of the compressor, and also the axial velocity of the air as it passes through the engine, by doing so we are encouraging the onset of stall and surge. Methods of ensuring that this does not happen have to be fitted to the engine, the following is a list of some of those methods:

- a) Variable Inlet Guide Vanes (VIGVs).
- b) Variable Stator Vanes.

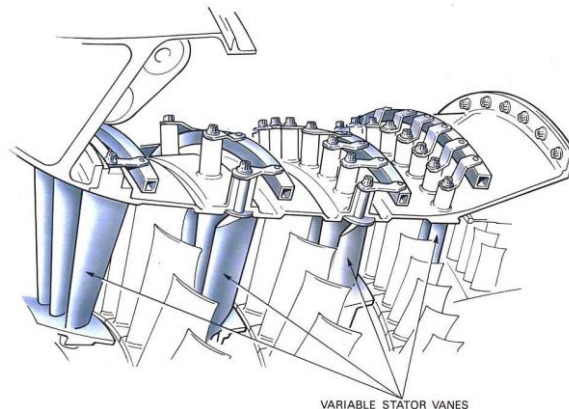

**FIG. 3.** Variable stator vanes

- c) Compressor Bleeds.

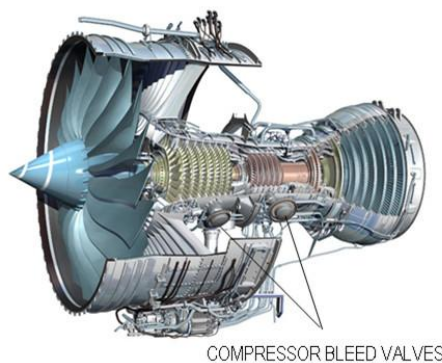

**FIG. 4.** Compressor bleed valves



- d) Multi-spool Compressors.
- e) Active Clearance Control.

#### 4. CONSTRUCTION

The rotor shaft is supported in bearings and is coupled to the turbine shaft so that minor variations in alignment are allowed for. The centrifugal load imposed on the compressor dictates that the rotor blades are fixed to a disc which itself is fitted around the rotor shaft. The types of fixing methods vary, the most common being that where the root of the blade is shaped into a dovetail joint and secured to the disc by a pin or locking tab. On smaller engines it becomes more and more difficult to design a practical fixing method and at the same time maintain minimum disc weight.

The rotor blades are of aerofoil section and are normally made from drop forged stainless steel, machined to a close tolerance before being attached to the rotor disc. The blades reduce in size from the front to the rear of the compressor, to accommodate the convergent shape of the air annulus. Some of the low pressure stages may have blades manufactured from titanium where the temperature of compression are not too high. The method of fixing, usually the dovetail system, does not ensure that the blade is held immovable in the disc, in fact the blades are quite loose until firmly seated by centrifugal force during engine operation, so that when windmilling on the ground the blades rattle loosely and sound somewhat like a bag of nails being shaken.



**FIG. 5.** A typical compressor rotor blade

The stator vanes are also aerofoil shaped and are fixed to the compressor casing either directly or into stator vane retaining rings, which are themselves fastened to the casing. The vanes may be assembled in segments in the earlier stages, and the longer ones are shrouded at their inner ends to prevent vibration which can be induced by the velocity flow over them. Early engines used aluminium alloys in the manufacture of stator vanes but they did not withstand foreign object ingestion damage at all well. Steel or nickel based alloys have a high fatigue strength and are less easily cracked or eroded by impact. Titanium is sometimes used for the vanes in the early stages, but it is not suitable further down the engine where the high temperatures can affect it. Another problem which may happen is that of rub, an excess of which might occur through mechanical failure, sufficient heat from friction would then be generated to ignite the titanium causing at best expensive repairs, or at worst an airworthiness hazard.

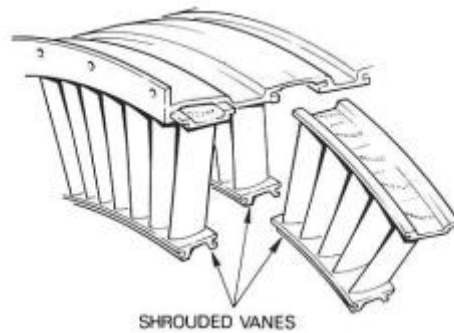

**FIG. 6.** Segments of shrouded stator vanes

The high bypass ratio engine's low pressure compressor blades, more commonly known as the fan blades, were initially manufactured from solid titanium, this material having the properties of strength with lightness. A low blade weight is essential if the fan is to be able to withstand the out of balance forces which would occur if a blade failed. Notwithstanding the enormous strength of titanium, the blades had to have incorporated into their design a snubber. This was a support fitted at mid-span which prevented aerodynamic instability, unfortunately it also added weight, and, particularly when two of them were required, it interfered with the supersonic flow characteristics of the air at the extremities of the blade. Experiments with new materials, particularly carbon fibre, were carried out, but its flexibility greatly reduced its effectiveness and its use has largely been discontinued. The greatest advancement has been achieved by fabricating the blade from a honeycomb core sandwiched between two outer skins of titanium. This method gives added strength with less weight, enabling the introduction of the wide chord and therefore the snubber is no longer necessary.

## CONCLUSIONS

The purpose of this review is to present a very important part of the jet engine, the compressor. It implies a hard work from engine manufacturers to design a compressor. Engine compressors have numerous uses. They are a vital part of a turbine engine, providing the high-pressure, high-temperature air for combustion as well as bleed air for system operation. Most modern passenger and military aircraft are powered by gas turbine engines, so compressors are tried to be made more and more reliable and efficient.

## REFERENCES

- [1] Oxford Aviation Academy (2010). *Powerplant*;
- [2] Jack D. Mattingly, *Elements of Gas Turbine Propulsion* (AIAA Education), American Institute of Aeronautics and Astronautics, Virginia, 2003;
- [3] [http://www.cast-safety.org/pdf/3\\_engine\\_fundamentals.pdf](http://www.cast-safety.org/pdf/3_engine_fundamentals.pdf);
- [4] [http://cset.mnsu.edu/engagethermo/components\\_gasturbine.html](http://cset.mnsu.edu/engagethermo/components_gasturbine.html);
- [5] <http://www.aviationpros.com/article/10387158/turbine-engine-compressor-sections-basic-theory-and-operation>.

## CONSIDERATIONS ABOUT GEOGRAPHICAL INFORMATIONAL SYSTEMS

**Alexandru ANTAL , Adrian Andrei NEGURA**

"Henri Coanda" Air Force Academy, Brasov, Romania (antal.allexandru@gmail.com  
andreynegura\_2011@yahoo.com )

**Abstract:** *As the world seems to be shrinking and our lives are becoming more directly affected by global events, the demand for geographical information increases. The instruments of the geography give the answer to the relevant issues of the moment: what can we do to stop the spread of diseases from one region to another, how can we predict and influence global climate changes effects, how we develop our ability to predict and respond to natural disasters, etc.*

*The present work proposes an analysis about technical and informational elements, which compose the present Geographic Information Systems in an attempt to make clear how great the decision-making factor influences the work procedures in all areas.*

**Keywords:** *geospatial, geostatica, screens, feature class, ArcScene, ArcGlobe, georeferencing.*

**Symbols and acronyms:**

GIS	Geographical Information System	OGC	Open Geospatial Consortium
SQL	Structured Query Language	ESRI	Environmental System Research Institute

### 1. GENERAL CONCEPTS

#### 1.1 INTRODUCTION

Geographical informational systems have been defined by the OGC as a computer system used for storing, checking, integrating, capturing, viewing and analyzing geospatial or geographical data through a computerized process. Geographical data are mainly related to the geo space location, characteristics of objects, natural and human constructed and their limitation on the surface of the Earth, see Figure 1.

Geographical informational systems have application in various fields: tourism, regional development, military domain, geology, hydrology, transportation, communications, health, environment, see Figure 2. Meteorologists use mathematical models using data from geographical informational systems to determine in real-time a range of important parameters for monitoring activity.

The use of geographical informational systems on a large scale is due to its capacity and capability of analysis, modeling and storage of information. An important contribution in the development of these systems, belong to the fields such as artificial intelligence, mathematics, physics, informatics and cybernetics.

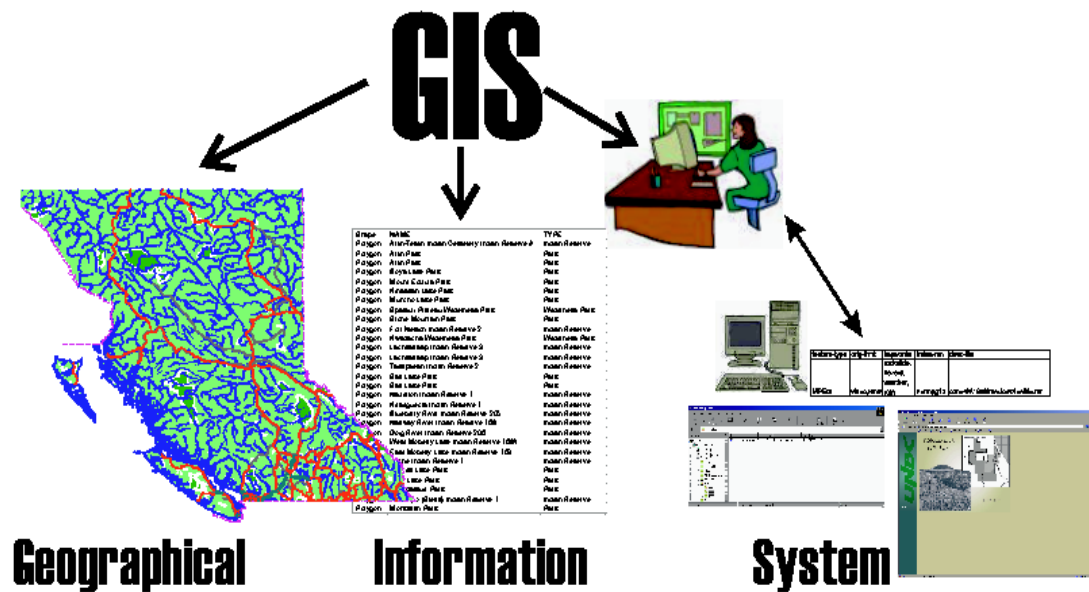
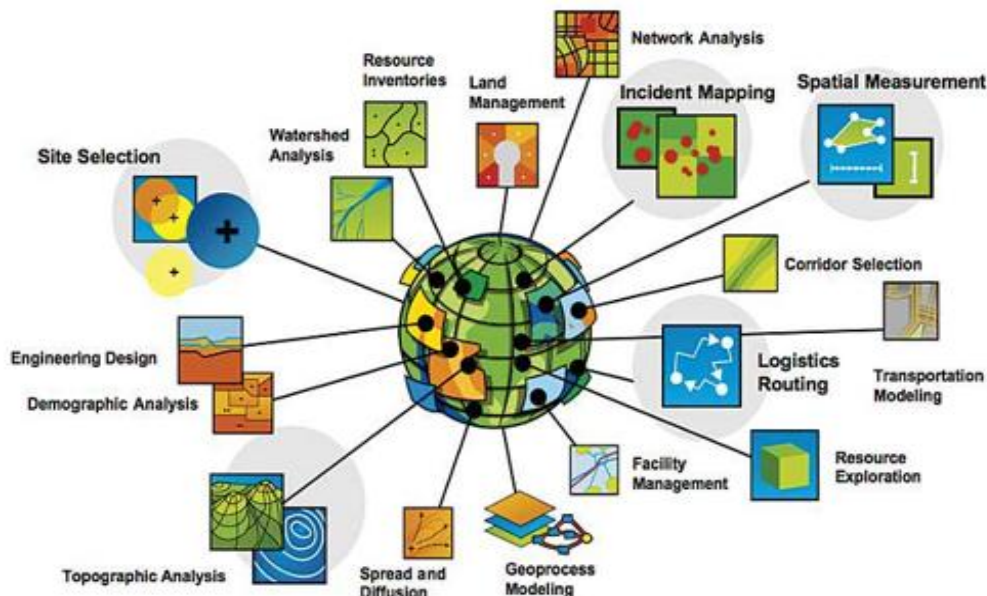

FIG.1. Geographical Informational System [1]

This technology process data using geo statistics, in this way combining scientific knowledge with available data becomes an important tool, a way of analysis or a way of examining data by identifying relationships, patterns or anomalies that would otherwise not be apparent. Functions and data from geographical informational systems become a tool for urban management, being a platform for decision support.

### GIS Is Being Applied Around the World Across Many Disciplines, Professions, and Organizations



*Becoming an Instrument of Evolution*

FIG. 2. Application of GIS [3]

## 1.2. OVERVIEW

In 1967, the National Film Board of Canada produced the movie "**Date for Decision**" about Canada Geographic Information System in which presents the first usage of the term GIS in any official document. GIS technologies are used for a wide range of applications and, as a result, there are different definitions of the term GIS.

GIS represents the computer system that pairs a database operating with geometric objects (spatial) with a database that uses the attributes of the information contained in the first database. [2]

Any important GIS performs a function, support a spatial database, which compiles information graphics (positioning in relation to various reference systems, systems of coordination).

A GIS offers the possibility to assign information to graphic maps. It integrates and analyzes data from various sources: thematic maps, diction data, weather, demographic data.

A geographic system incorporates data on location, shape, relationship between geospatial attributes and facts about the environment. GIS are designed to determine the correspondence between different objects of that space using geographical units defined to which they were assigned a description.

In essence, a GIS offers the possibility to assign information to graphic objects of maps and creating new relationships and connections that can determine, for example, if a given area meets the conditions necessary for investment. At the same time, assesses the impact of GIS to various environmental factors, identifies the best place for the location of a new goal.

## 1.3 THE COMPOSITION AND REQUIRMENTS OF A GIS

a) *the Composition.* A geographic information system for operation requires five components , see Figure 3.

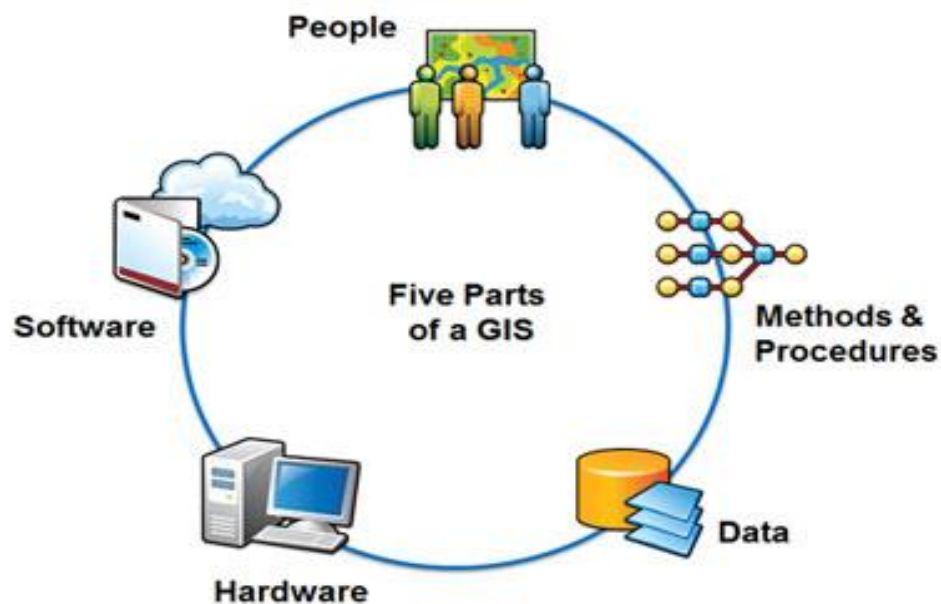

FIG.3. GIS system components. [5]

If a component is missing then the operation of GIS can be compromised. The contribution of each component, however, is different. In terms of costs, if the hardware is considered to be a unit of cost, the cost of the programs is between 2 and 5, then the costs for obtaining and processing rises to 100. For this reason it can be appreciated that the accumulated reason to obtain correct data has a very high importance in the task of achieving a GIS project. The most widely used GIS in the world is produced by ESRI. This is the organization that produces (Arc Info), the widest user base worldwide, provides continuous support, documentation of best quality and wide educational programs, it was the pioneer in industrial development of GIS software. ESRI offers a wide range of products such as: GIS, Arc Info, Arc Scene for world leader of GIS products Expert.

b) *Requirements*. Being a computer system, a GIS must meet certain requirements at the same time, as shown in Figure 4.



**FIG.4.** GIS system requirements

All GIS users want a flexible and complete data model, an open system and independent hardware, an approach combining the management of the data base with a cartographic production, friendly and a complete set of spatial analysis functions.

## **2. REPRESENTATION OF GEOSPATIAL INFORMATION WITH GIS**

Without exception, as a support for all the work of GIS are the geographical data sets which contain the details necessary for the development of databases, maps and analyses. One of the main roles of a GIS is helping us to organize effectively these geographic data. Although they are similar to data created and stored in various software programs, GIS data have some unique characteristics.

GIS data are digital representations or models of spatial objects or phenomena that occur on the Earth's surface and in its proximity, see Figure 7. The majority of space objects and phenomena can be modeled and stored as GIS data.

Geographic objects can be described by three methods: their position in line with the Earth's surface, the descriptive traits (attributes), geographical relations in line with other geographical objects. Whatever data structure of a GIS is necessary to take into account these properties. The attributes of an geo space object may change over time without making any changes to the shape and position, it is very important that the limitation and separation of graphical and non-graphical data encoding. [11]

There is a number of models for the representation of these varieties of geographical entities, two of them being the most common. One geographical entity that represents geometric shapes (feature class); Another is that the values of the pixels (raster). [4] The typical representations of the characteristics of classes are the points (wells), lines (roads) and polygons (areas with population), see Figure 5. The characteristics of the class are stored as pairs of coordinates in relation to the location of the Earth's surface. A line or polygon can be represented as a series of coordinated pairs that can be connected to draw an object space. This approach illustrates the spatial objects as discrete objects on the Earth's surface, and their representation as compared to the data vector. [3]



**FIG.5.** Creating points for locations, networks of streets and parks limits are examples of feature class [8.10]

By contrast, the geographic dividing screens represent Earth objects in separate cells of rectangular or square shape organized into a network, as shown in Figure 6. Each cell describing a phenomenon after it was noticed. Raster data Structure is often used for categories of data (such as land cover), digital elevation models and satellite images.

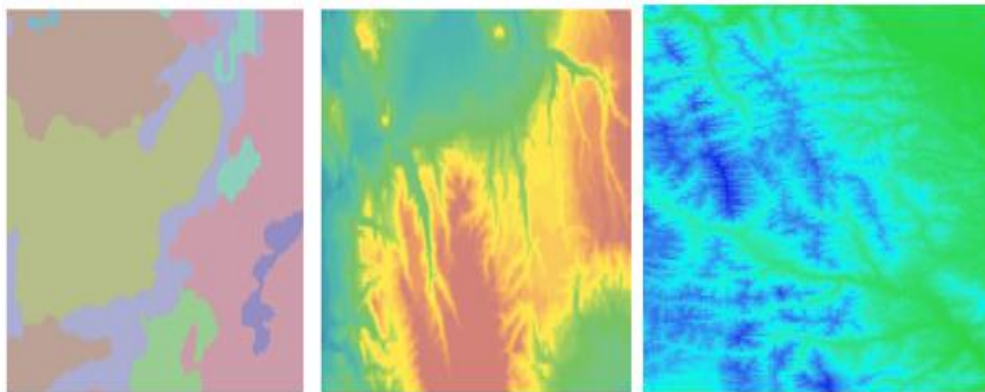

**FIG.6.** Examples of screens depicting vegetation [3]

Cell values can be any values measured or calculated, such as altitude, inclination of the slopes, precipitation, vegetation types or temperatures.

Although most of the geographical object can be represented using either one of these approaches, it is more appropriate if you use just one of them. Often one can work with both simultaneously for maps or analysis.

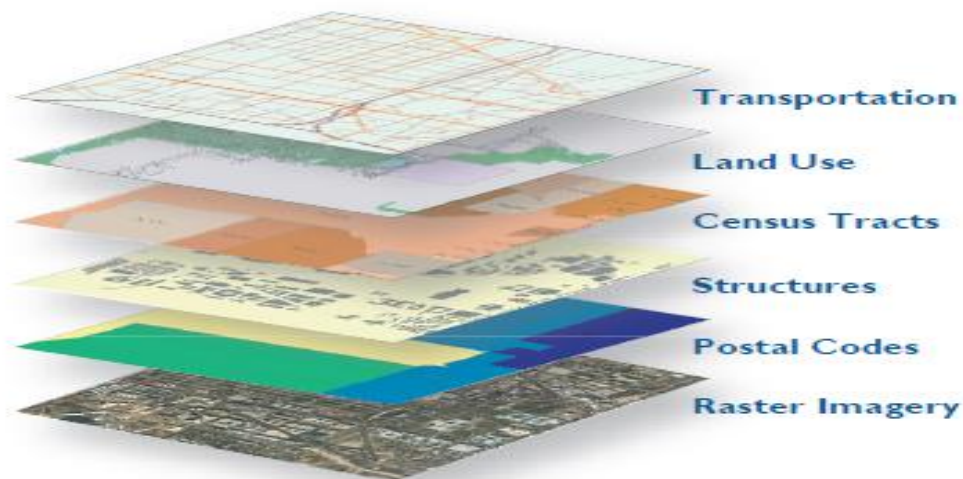

FIG. 7. The representation of the various types of data

### 3. REPRESENTATION OF SPATIAL OBJECTS IN GIS ATTRIBUTES

In GIS attributes feature class are stored and managed in tables, which are based on a series of relational database concepts, these include: *tables* (containing rows, all rows in the table have the same columns, each column has a data type, such as whole numbers, decimals, number, date); *relationships* (which are used to associate rows in a table with rows of another table, they are based on a column and a municipality in each table); a number of SQL functions and operators to operate in tables and their data, as shown in Figure 8. [11]

Feature class table

Shape	ID	PIN	Area	Addr	Code
	1	334-1626-001	7,342	341 Cherry Ct.	SFR
	2	334-1626-002	8,020	343 Cherry Ct.	UND
	3	334-1626-003	10,031	345 Cherry Ct.	SFR
	4	334-1626-004	9,254	347 Cherry Ct.	SFR
	5	334-1626-005	8,856	348 Cherry Ct.	UND
	6	334-1626-006	9,975	346 Cherry Ct.	SFR
	7	334-1626-007	8,230	344 Cherry Ct.	SFR
	8	334-1626-008	8,645	342 Cherry Ct.	SFR

Related ownership table

PIN	Owner	Acq.Date	Assessed	TaxStat
334-1626-001	G. Hall	1995/10/20	\$115,500.00	02
334-1626-002	H. L. Holmes	1993/10/06	\$24,375.00	01
334-1626-003	W. Rodgers	1980/09/24	\$175,500.00	02
334-1626-004	J. Williamson	1974/09/20	\$135,750.00	02
334-1626-005	P. Goodman	1966/06/06	\$30,350.00	02
334-1626-006	K. Staley	1942/10/24	\$120,750.00	02
334-1626-007	J. Dormandy	1996/01/27	\$110,650.00	01
334-1626-008	S. Goolley	2000/05/31	\$145,750.00	02

FIG. 8. Example of tables that can be linked by a common field-in this case, [16]

#### 3.1 THE ESTABLISHMENT OF THE SYSTEM FOR A SET OF DATA FROM THE SURFACE OF THE EARTH

A key concept for GIS data is related to the fact that a set of data has a location on or near the Earth's surface. This concept leads to a separation of the GIS data from other programs, in which the objects are stored in the page. Because the data is linked to a real location on the Earth's surface, you can sketch the shape as it is being done on a new page in a graphics program. [12]



The data sets are stored using the coordinates corresponding to the position of the Earth's surface. Coordinates must convey accurate positions, so that forms of spatial objects and the relationships between them reflect actual conditions on the Earth's surface. Description of the location of the space objects requires a framework for defining the real location. This process is called geo referencing. Geo Reference is accomplished by specifying the coordinate system of the data set, see fig. 9.

Geo Reference allows displaying on a single map, various sets of data from different sources and overlaying or combining data sets that represent the same location to derive new data and information. If the data sets are set in the page then two data sets with the same location will not overlap. Once geo referenced, the data sets will have the same frame of reference, and will overlap correctly, see Figure 10. [12]

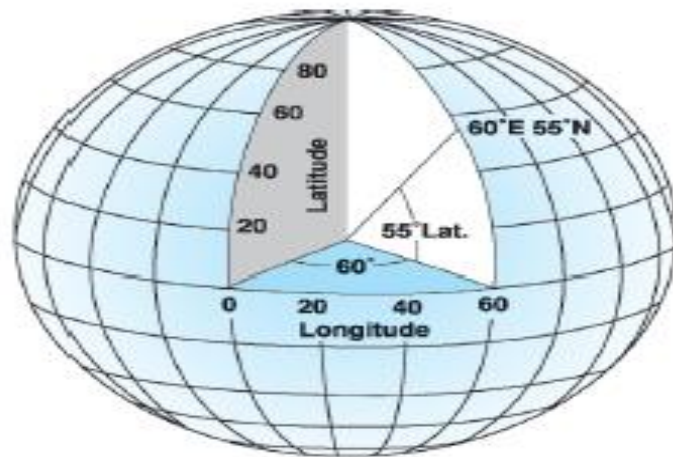

**FIG. 9.** The geographic reference system [10]

Each set of GIS database has a set of properties that defines specific details about their system of coordinates. Once specified, the defined coordinate system is stored with the data set.

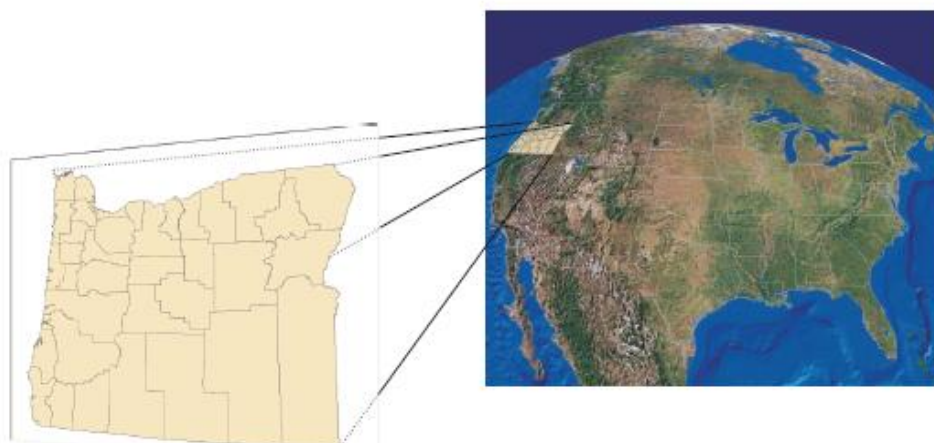

**FIG. 10.** Display Mode in GIS-on a computer screen or map-geographic objects on the surface of the spherical Earth. [10]

Display Mode in GIS-on a computer screen or map-of the geographic objects on the surface of a spherical Earth, point on the Earth's surface. This frame of reference is often related to the geographic coordinate system.

Although the longitude and latitude can locate the exact position on the surface of the globe, this coordinate system does not allow accurate measurement of distances or areas or displaying data with ease on your computer screen or on the map.

Cartesian coordinate system uses two axes: one horizontal (x) for the East-West direction and a vertical (y) direction North-South. The point where the axes intersect is called the origin. The location of the geographical object is defined by reference to the original, using the notation (x, y), where x refers to the distance along the horizontal axis and y refers to the distance on the vertical axis. [10]

## CONCLUSIONS

Geographic information systems represents today one of the most important technologies that have turned into a peculiar manner about how it is done the research by geographers for the benefit of the society. A major impact it has on those who use GIS, due to the fact that it has been used in a manner pleasing to everyday life. The manner in which the information is entered, analyzed and stored within a GIS system, must clearly show how the data will be used for research or for certain situations that require immediate action, such as measures of fighting against natural disasters.

Wide range of GIS applications illustrates the value as a tool for risk management and development planning. As shown, the geographic information systems can improve the quality and power of analysis of natural hazard assessments, to guide development activities and to assist planners in selecting the measures of improving and implementing measures for emergency situations and response actions.

## REFERENCES

- [1] [www.alnozom-egypt.com](http://www.alnozom-egypt.com)
- [2] <http://www.theotop.ro/GIS-RD1/>
- [3] <http://www.esri.com/news/arcnews/fall07/articles/gis-the-geographic-approach.html>
- [4] <http://wiki.gis.com/wiki/index.php/Digitizing>
- [5] <http://www.kzrec.co.ir/?part=menu&inc=menu&id=574&>
- [6] <http://earthexplorer.usgs.gov/>
- [7] <http://gdem.ersdac.jspacesystems.or.jp/>
- [8] <https://desktop.arcgis.com/en/arcmap/latest/manage-data/las-dataset/what-is-lidar-data-.htm>
- [9] <https://www.oas.org/dsd/publications/Unit/oea66e/ch05.htm>
- [10] <http://www.cs.utah.edu/~arul/gis.pdf>
- [11] <http://earthexplorer.usgs.gov/>
- [12] Peter Dale, Mathematical Techniques in GIS Second Edition-13, ISBN 978-1-4665-9555-2 (eBook - PDF)

## GENERAL ASPECTS REGARDING INFORMATIONAL WARFARE

Georgian - Cosmin CONSTANTIN

"Henri Coanda" Air Force Academy, Brasov, Romania (cpop@afahc.ro)

**Abstract:** *Informational warfare is a form of conflict specific for the 20'th century and the beginning of the 21'st century and through its ongoing operations becomes an instrument of strategic discouraging both locally and globally. It can be defined as a method of negation, exploiting, distortion or destruction of the enemy's information, command, control and processing resources while protecting one's own available resources and exploiting the numerous functions of military information. Being an entirely different kind of conflict, it is continuously present around us and it often goes unnoticed for the public. After all, the informational warfare is based mainly on knowledge of the laws of psychology and how to apply them in certain environments.*

**Keywords:** *modern warfare, media, propaganda, informational warfare*

### 1. INTRODUCTION

War is an expression of the reality that is at its limits, or even beyond them, of the human society's tendency for conflicts. It can be somehow compared to a climbing of Mount Everest in unfavorable conditions and it presents itself as some kind of bizarre attitude, brave lack of awareness or evil power, capable of changing or transforming what is real into something imaginary, and what is imaginary into something real, the logic of truth into the truth of a new logic, one of paradox interferences.<sup>[1]</sup>

Modern warfare is very expensive, both physically and psychologically, and that is why it is not possible for it to become a prolonged armed confrontation. No matter what shape the modern warfare takes, it requires a very high level of implication from the involved parties, which often is difficult to maintain.

The concept where attacking forces use a strategy of quick actions and the attacked ones carefully react and try to use time to their advantage is no longer available during modern warfare.

### 2. MEDIA WARFARE

Quoting Călin Hentea, the media warfare is the confrontation between mass media belonging to groups which are in an armed conflict, to impose both to their own public opinion and to the international one its own version in regard to causes, courses of action and consequences. *"In a larger sense, media warfare includes the whole specter on confrontations, exclusively carried by mass-media both between the press belonging to conflicted sides and between different mass-media components belonging to the same side, concerning the ongoing conflicts and the matter of imposing their adopted points of view."*<sup>[2]</sup>

Basically, media warfare consists of two main components, as is the case for every type of warfare: the offensive and the defensive sides. Both of them are represented by different states that are in armed conflict.

Media warfare is often not noticed by the majority of the population, mainly because of their lack of education and interest, and that is why it is one of the most used type of modern warfare. The ways of fighting are adapted to the “weapons” involved in confrontations: information, words and images.

There are numerous ways through which media warfare achieves its purpose, and some of them are represented by the public relations structures, limited access to information, censorship, disinformation, intoxicating the public with non-valid, outdated or irrelevant information, propaganda and manipulation. Those are nothing but means to influencing the public and they usually have common points, which determines them to intersect and complete each other.

Media warfare, through its complex components, was used for the first time during the Crimean war. It was the first time when a war correspondent and a photographer had a remarkable contribution during a conflict, making it possible to capture and publicly analyze through the press the ongoing events. Moreover, it was the first time when the press could directly express its critic opinions concerning such events and the information was quickly passed on to the public.



**FIG. 1.** Balaklava looking seawards, the Commandant's house in the foreground. Balaklava looking seaward showing general view of the landscape and buildings with the Commandant's house in the foreground, behind which, to the right, is the ordnance wharf and the harbor with a line of ships receding to the middle distance, and in the upper left corner, the remains of the old Genoese castle perched on the hills that line the harbor. Photography taken by Roger Fenton during the Crimean War. Photo courtesy of [www.allworldwars.com](http://www.allworldwars.com) <sup>[5]</sup>

### 3. IMAGOLOGICAL WARFARE, PROPAGANDA AND PSYCHOLOGICAL WARFARE

Imagological warfare can be defined as the deliberate actions concentrated towards an institution or public or private structure in order to impose a negative public image of the adversary in the minds of a certain society, while protecting one's own image. <sup>[3]</sup>

The most frequently used method in this case is "demonizing" the enemy.

Still, there are many other methods of implying this kind of warfare: in some cases, the leader's image was attacked, while the population was being victimized, while in other cases both the leaders and the population's image had to suffer. There are numerous examples that demonstrate the effects of undergoing such actions, like the Meldive war, where both General L. Galtieri and his people were being criticized. During the Gulf War, the Americans and president Bush were demonized by Sadam Hussein and his allies, but there are also cases where the people were considered victims: the Romanian revolution and Nicolae Ceaușescu, or Panama, where Manuel Norriega was considered "the public enemy".

Propaganda is somehow related. It is often the main enemy discouraging method, initially considered a perfectly honorable concept-spreading method. It's sense had degraded through repeated use, slowly becoming an action of persuasion that replaces rational thinking with the ability to impress, and sometimes the messages received can't be considered entirely true.

It is usually so well embedded inside the mass-media that it is often hard to realize what the hidden subliminal transmitted message really is. Today's television has reached a credibility scale which tends to the maximum, especially through live transmissions, and that is why the public has a tendency to receive information in its raw state rather than analyze it.

As Dona Tudor states, "*the virtual image is tele-presenting, rather than representing: inside the virtual reality, images become realities*". <sup>[4]</sup>

He also states that our culture is no longer the result of a directional activity of our personality created by education, but rather the result of a continuous flux of fragmented information coming from a permanent output of the surrounding environment.

Psychological warfare, as Calin Hentea defines it, is a "*confrontation taking place for control over people's minds*". <sup>[3]</sup>

The control that he talks about can be realized with mass-media's help, the messages transmitted this way being so carefully processed that a large part of the public no longer has the capacity of differentiating the truth from the irrelevant or incorrect information.

### CONCLUSIONS

Developments in recent years attest that we are witnessing the materialization of a new type of aggression, a new kind of war, an invisible war, unnoticed by the majority of the population, mainly because of the public's low training in this area but also because of the low levels of interest on this issue.

The informational warfare's characteristics and subtle and effective manifestations far exceed those of classic war. Moreover, the variety of types of warfare based on the power of the word, especially to information, leads to forms of war that are quite cheap compared to other methods.

A public that is not educated to carefully analyze and assess information is more likely to become a target of such actions. Unfortunately, the modern society still has to develop a way of surpassing the vulnerability created by the increased examples of informational inadvertences.

## REFERENCES

- [1] G. Văduva, *Război și cunoaștere*, București, Universitatea Națională de Apărare “Carol I”, 2008;
- [2] C. Hentea, *150 de ani de război mediatic. Armata și presa în timp de război*, Bucharest, Nemira, 2000;
- [3] C. Hentea, *Propaganda fără frontiere*, București, Nemira, 2002;
- [4] T. Dona, *Manipularea opiniei publice în conflictele armate*, Cluj-Napoca, Dacia, 2001;
- [5] Crimean War Photographs, URL: <http://www.allworldwars.com/Crimean-War-Photographs-by-Roger-Fenton-1855.html>, visited on February 16th, 2017, 19:45;

## PROPELLER OPERATING ISSUES IN SINGLE ENGINE AIRPLANES

Nicolae Eduard ȘMALBERGHER

"Henri Coanda" Air Force Academy, Brasov, Romania (cpop@afahc.ro)

**Abstract:** *Airplanes have always had various designs, more or less complex. The main purpose of this paper is to exhibit the operating issues in single engine, propeller powered airplanes. It presents the nature of propeller thrust, stating and explaining the effects derived from it, along with pilot means of action for controlling them. The paper also explains how an aircraft will behave under the influence of propeller thrust effects, so that they can be better understood, especially in critical moments such as take-off, even considering exterior factors (wind).*

**Keywords:** *propeller, thrust, slipstream, torque, gyroscope, precession, asymmetric, angle of attack, lift.*

### 1. INTRODUCTION

Most general aviation aircraft and first level trainers are powered by a propeller. The purpose of a propeller is to generate propulsive thrust from the power of the engine.

Thrust is the force which moves any aircraft through the air. Thrust is generated by the propulsion system of the aircraft. Different propulsion systems develop thrust in different ways, but all thrust is generated through some application of Newton's third law of motion. For every action there is an equal and opposite reaction. In any propulsion system, a working fluid is accelerated by the system and the reaction to this acceleration produces a force on the system. A general derivation of the thrust equation shows that the amount of thrust generated depends on the mass flow through the engine and the change in velocity of the gas going through the propulsion system.

The theory of how a propeller produces thrust is very complex, but put simply, there are two principles explaining the nature of propeller thrust:

- In accordance with Newton's third law, the propeller accelerates a mass of air rearwards, causing it to move in the opposite direction.
- The propeller acts as a rotating wing, because its blades are airfoils which cause a difference in static pressure across them.

Some aerodynamicists treat the "wing theory" view and the "momentum theory" view as two separate concepts, each having a partial contribution to total propeller thrust, while others treat the two concepts as being just two parts of a single concept of thrust, ultimately based on the momentum theory.

Given the complexity of the propeller thrust theory, a pilot should always be aware and understand the effects of its dual nature explained in this paper.

## 2. THE SLIPSTREAM EFFECT

A rotating propeller will generate an airflow travelling backwards in a helical path along the fuselage. If the propeller rotates clockwise, the slipstream will meet the fin and rudder, producing an aerodynamic force on the vertical empennage acting to the right, which causes the plane to yaw left. The opposite thing happens if the propeller rotates anti-clockwise. [1,2]

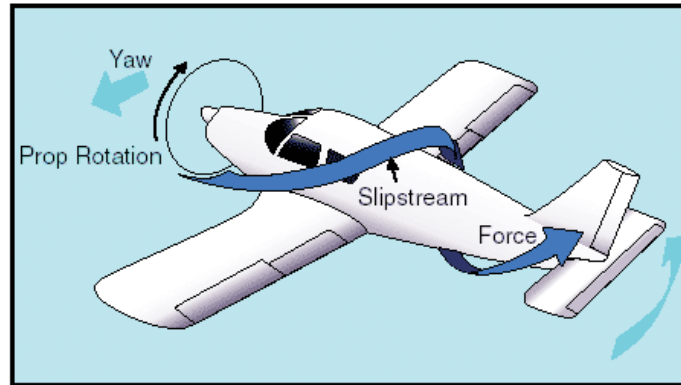

**FIG. 2.1** The propeller slipstream effect

At the aircraft's cruise speed, when flying straight and level, this effect is normally eliminated by the manufacturer's trim setting, or can be manually eliminated by the pilot using the rudder trimmer, if the aircraft has one.

However, this effect can cause a marked yaw when full power is applied at the beginning of take-off roll. It can also cause yawing in flight, when power settings are changed. When power is applied, the aircraft will yaw in the opposite direction of the propeller rotation, and when it is reduced the aircraft will yaw in the direction of propeller rotation. In all these situations the pilot must prevent yaw by applying an appropriate rudder pressure.

The magnitude and effect of the spiraling slipstream varies greatly between aircraft designs, as such, no easy rules of thumb can be provided to isolate these forces from other propeller phenomenon. It is the result of the air circulating around the aircraft because the propeller imparts such motion to it. [2]

The rotating air changes the direction of the local airflow at the side of the fuselage and vertical stabilizer, causing a yawing moment to the left (for clockwise prop rotation; it may also contribute to a pitching moment and rolling moment). This phenomenon varies with aircraft design, power setting, angle of attack, and airspeed, both in effect and magnitude.

## 3. PROPELLER TORQUE EFFECT

The propeller also reacts to engine torque, which causes propeller torque. This enables the propeller to absorb the engine torque, but also causes the aircraft to rotate about the propeller shaft in the opposite direction of the propeller rotation.

When taking off, this rotation is resisted mostly by the undercarriage, which causes a swing opposite to the propeller rotation due to different values of the force acting on the main wheels, as seen in figure 3.1.

In flight this effect can cause the aircraft to turn in the opposite direction of the propeller rotation. This tendency is countered by moving or trimming the aileron.



At the same time, this correction can induce adverse yaw, which is corrected by moving or trimming the rudder.

This effect is more evident during the early stages of the take-off and is important to know that the swing induced by propeller torque effect is in the same direction as the swing induced by propeller slipstream effect.

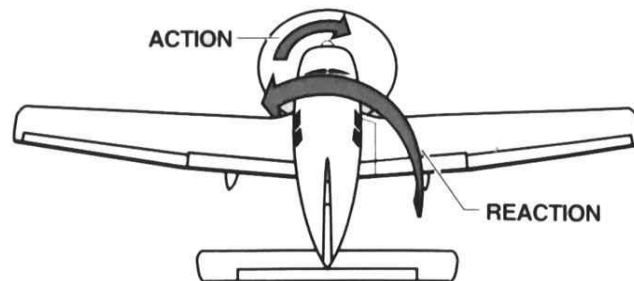
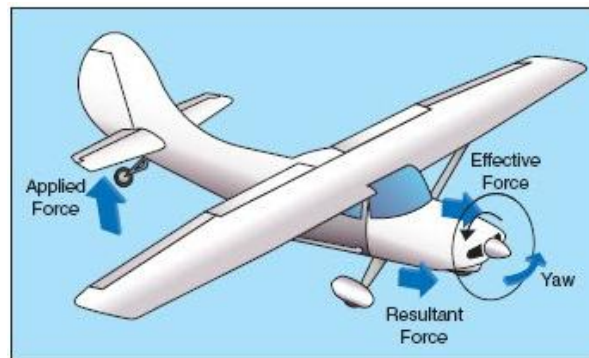

**FIG 3.1** The propeller torque effect

#### 4. THE GYROSCOPIC EFFECT

A gyroscope is any object spinning around its axis. That being said, the propeller itself is a gyroscope and any gyroscope reacts to forces applied to its spin axis. That reaction is called precession. The result of precession is that any force applied to a gyroscope's spin axis takes effect at exactly 90° in the direction of spin. [2,3]

So, if a propeller is rotating clockwise as seen from the pilot's seat and the nose pitches downwards, this effect will cause the aircraft to yaw left (figure 4.1).



**FIG. 4.1** Gyroscopic precession in a propeller

This effect is more prominent in a tail-wheel aircraft during the take-off run, when full power is applied and the pilot lifts the aircraft's tail.

#### 5. ASYMMETRIC BLADE EFFECT

This effect is felt by the aircraft when the propeller's axis of rotation is inclined upwards to the horizontal path followed by the aircraft, or when the plane of rotation of the propeller is not vertical. This means that the down-going blade will travel a longer distance than the up-going blade in the same time, which means the relative airflow over the down-going blade will have a higher velocity. According to the wing theory, an increased velocity means an increased lift produced, and therefore increased thrust (equation 1).

$$L = \frac{1}{2} \rho v^2 S C_z \quad (1)$$

L = lift

$\rho$  = air density

v = airflow velocity

S = wing surface

$C_z$  = lift coefficient

Furthermore an increase in relative airflow velocity will cause an increase in blade angle of attack. Therefore, the down-going blade will have a higher angle of attack, which also leads to an increased thrust on this blade. [2,3]

Again, the effect must be countered by making an appropriate rudder input.

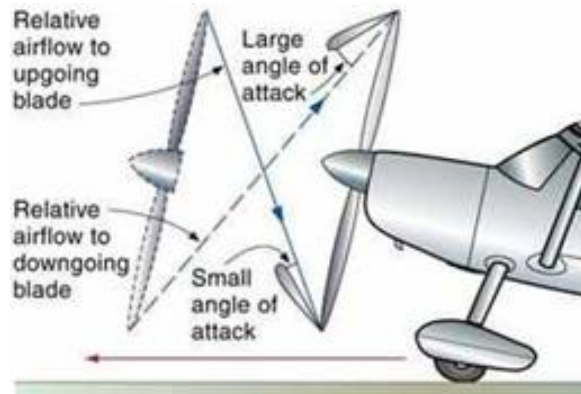

**FIG 5.1** The asymmetric blade effect.

## CONCLUSIONS

It is extremely important for a pilot operating a single engine, propeller powered aircraft to understand the nature of propeller thrust, its effects, and how to counter them.

Slipstream Effect, Torque Effect, Gyroscopic Effect, and Asymmetric Blade Effect all induce a swing to the same direction, and all the effects reinforce one another.

Also, wind can play an important role in accentuating or reducing the intensity of all the effects.

The most critical moment when all the effects occur is the take-off stage, especially when flying a tail wheel aircraft (because lifting the tail during take-off roll is required).

But these effects appear in all the stages of flight. For example, even if the aircraft is well trimmed in level flight, the pilot should be prepared to counter the effects when maneuvering.

Propeller thrust theory is complex and controversial, therefore operating issues will occur in aircraft powered by a single propeller, but this is the price to pay for low cost and structural simplicity. Pilots learn to overcome these issues, therefore this design will still remain a widely used one.

## REFERENCES

- [1] K. H. Falk, *Aircraft propeller handbook*, The Ronald press company, New York, 1943.
- [2] J. Kenny, *Principles of Flight*, Oxford Aviation Academy, Oxford, 2007.
- [3] J. Kenny, *Aeroplanes*, Oxford Aviation Academy, Oxford, 2007.

## HYDROGEN - FUTURISTIC FUEL FOR INTERNAL COMBUSTION ENGINES

**Marian VIJULIE, Larisa POPA**

Military Technical Academy, Bucharest, Romania ( marianvijulie@yahoo.com )

***Abstract:** In the past few years automotive companies have been searching for advantages to increase fuel millage in order to protect the environment, while still providing an entertaining driving experience for their customers. With gas prices on the rise, the average American wants a car that can do everyday activities whilst spending the least amount of fuel possible. Not only customers are demanding for better gas millage, but the government as well. In my paper I will attempt to address this issue by designing and building an HHO generator. This generator uses the principle of electrolysis to split water into its two molecules, hydrogen and oxygen, in gas form. This gas will be introduced into the combustion chamber of an engine to increase its power, burn less gas, and exhaust water particles out to the environment.*

***Keywords:** engine, electrolysis of water, hydrogen cell.*

### 1. INTRODUCTION

There are many forms of fuel-saving device that are available in the market. Fuel-saving device on gasoline fuel car is a device that is designed to minimize that use of gasoline fuel car. Nowadays, price for the fuel car is increased and the user needs to pay the expensive fuel for a few liters.

With such high demand for more efficient engines, my mission is to design and create a device that will increase engine efficiency without jeopardizing its performance. Such a device is an HHO Generator. This generator uses electric current (electrolysis) to produce hydrogen from water; the hydrogen will be introduced into the combustion chamber of an engine through the intake manifold.

Building this generator comes with some challenges. This includes coming up with a creative design to get as much hydrogen out with the least amount of current running through the cell. More concerns include implementing very conductive wires and plates into our system. Taking these aspects into consideration will make the HHO generator a productive addition to any internal combustion engine. The only problem with the hydrogen car is that since it's not in high demand there are only very few places where you can refuel. Thus the distance you can travel with the vehicle is limited. Dual-fuel internal combustion engine vehicles that combine gasoline and hydrogen could be the alternative solution to enthusiasts for speeding up the introduction of hydrogen in the vehicles. Vehicle conversion to dual-fuel operation is technically feasible and low cost.

## 2. FUEL CHARACTERISTICS OF HYDROGEN

### Water as combustion fuel

To understand how these water-fuel system work, it help to begin by realizing that ordinary water is actually a ‘battery’ containing vast amount of energy. Water is H<sub>2</sub>O- two part of hydrogen combined with one part oxygen. The amount of energy in the water molecule is thus vast, and has absolutely nothing to do with the amount of energy it takes to break down that molecule.

### Instant hydrogen gas

Using water electrolysis to produce hydrogen has been studied for a long time. Some records indicate that hydrogen has been used by man as an source in many different levels of fields such as commercial, military and industrial sectors since the late 19th century. Electrolysis is one of the favorite fields of the study and scientific experiment for many researchers all around the world . The electrical power source is connected to two electrodes that are made out of typical metal (such as stainless steel, platinum or titanium) which are in the electrolyte water , hydrogen will be produced at the negatively charged electrode (cathode) where the electron enters. The oxygen will be produced at the positively charged electrode (anode). Ideally the amount of hydrogen produced is twice the amount of the oxygen moles. Electrical charge conducted by the solution is proportional.

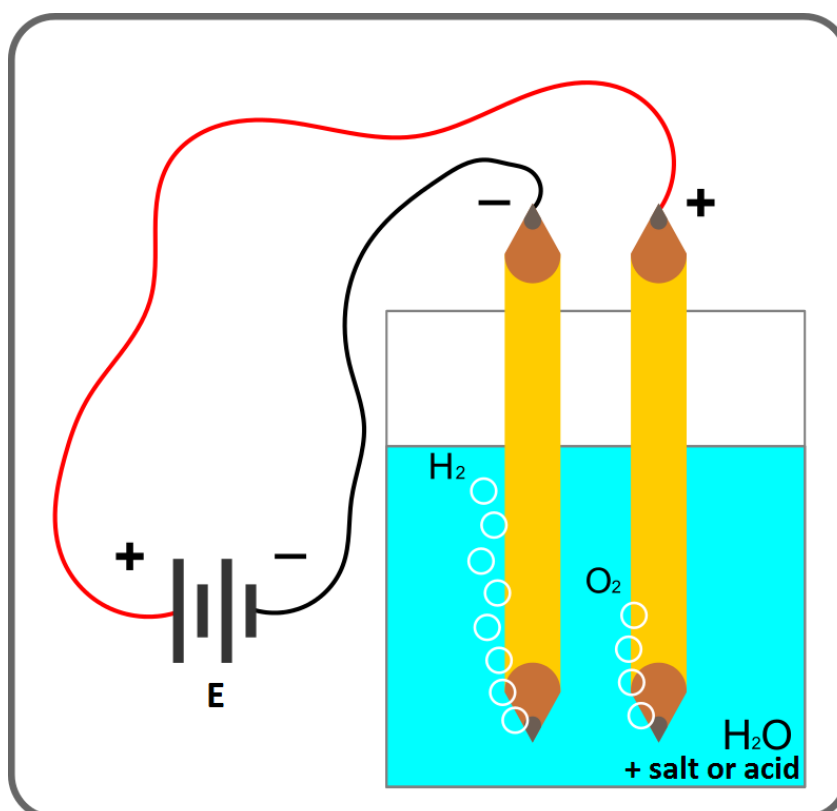

FIG. 1. Principle of Electrolysis

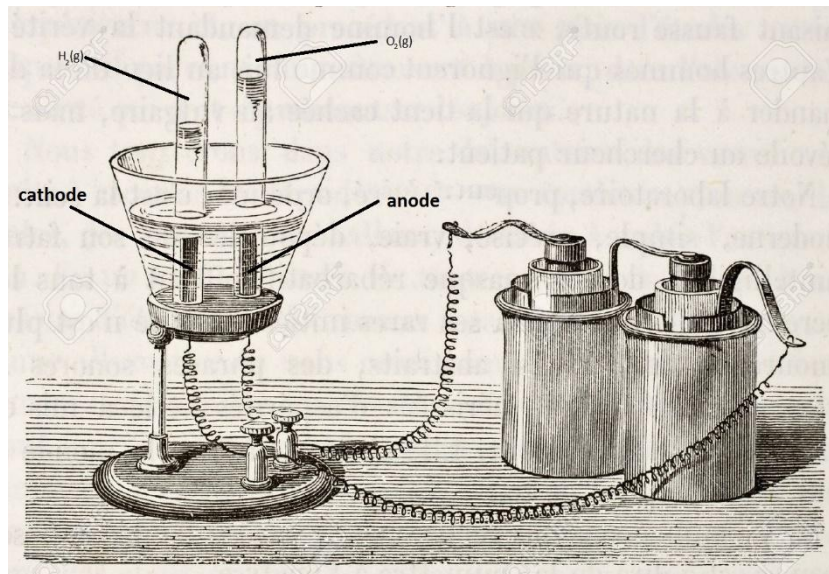
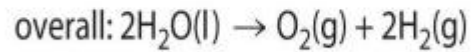
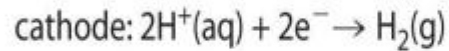
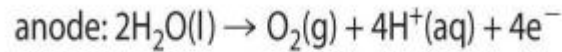

FIG. 2. Electrolysis Photograph

1. Design and build a practical and economical way to increase engine efficiency in combustion engines.
2. Build HHO generator that splits water's molecules, using the process of electrolysis. Yielding a mixture of hydrogen and oxygen gas, also known as HHO gas.
3. Adapt the generator in a conventional internal combustion engine to push the HHO gas into the air intake.

### 3. CONCEPTUAL AND PROPOSED DESIGN

In electrolysis, people have tried different ways to increase the output of gas while decreasing the input of current. Some designs are more effective than others. Some people have tried to improve the conventional way, called "wet system", consisting on plates or tubes submerged in water, while others have tried a design called "dry cell" where the water run through the plate.

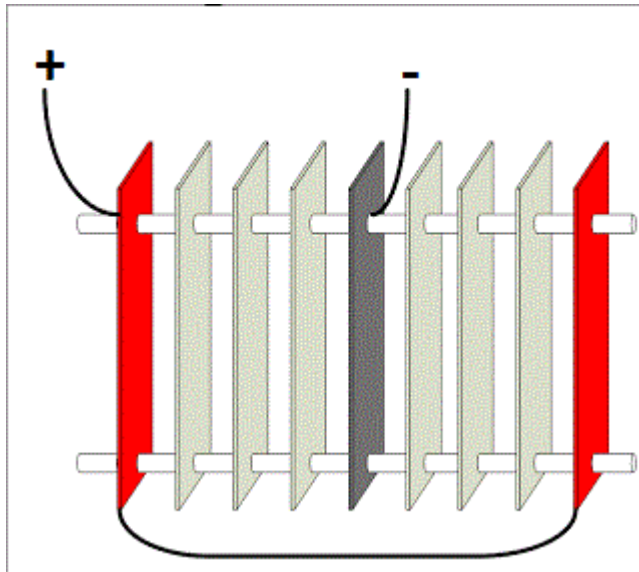

FIG. 3. Square Cell

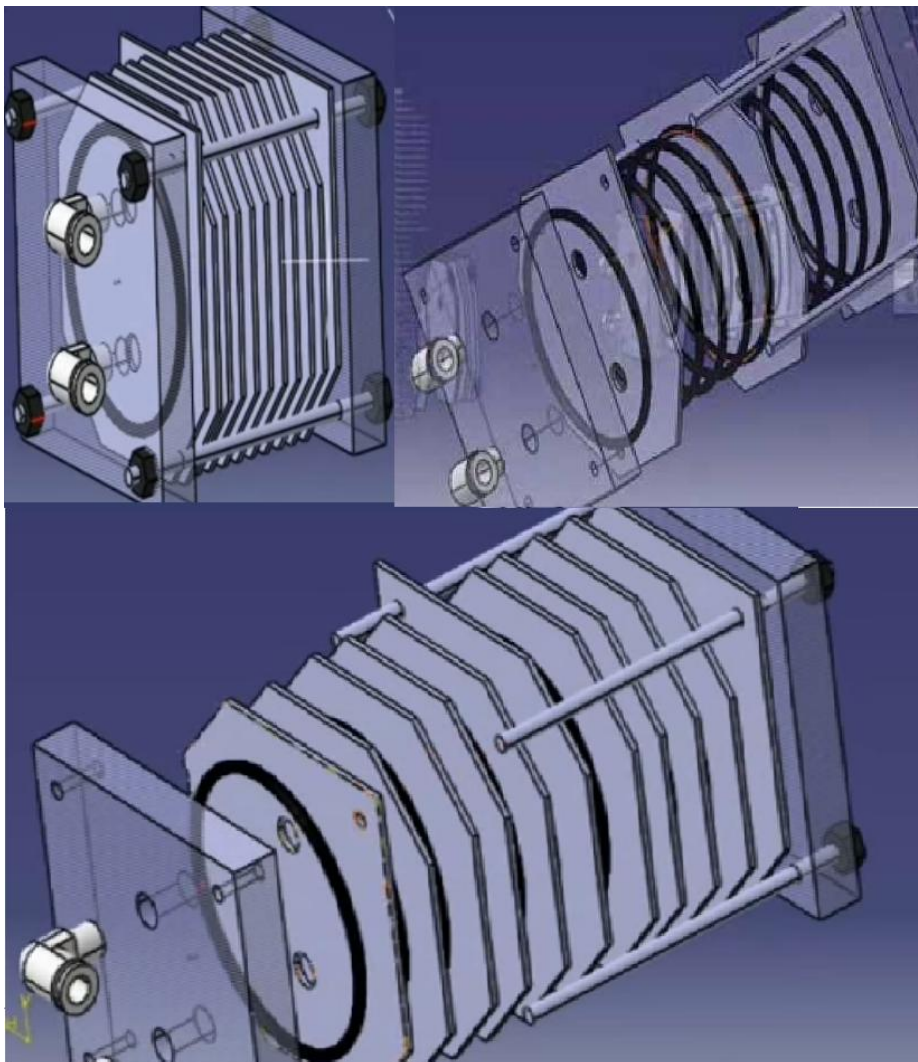

FIG. 4. Square Cell

Dry cell designs are cheaper. This design can vary in shape or size, making in it very easy to install anywhere. The material used for the plates is stainless steel and uses regular rubber O-rings to separate them. The pressure built inside, sometimes up to 60 psi. And very important, it has to be a dielectric material in order to avoid electrolysis between the tubes and the inner wall of the container.

The effectiveness of this system is higher than the dry cell system, although more current input is necessary the amount of hydrogen out is greater. Despite the cost of fabrication of this system and our limited budget we are choosing this design for our project in order to obtain a better production of hydrogen.

#### 4. ANALYTICAL ANALYSIS

In order to quantitate the process of electrolysis, we have found some equations that relate the current needed to obtain a certain volume for a gas. . The process for this calculation at room temperature and at 1 atm is:

1. Write the half-reactions that take place at the anode and at the cathode.

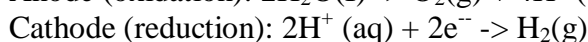
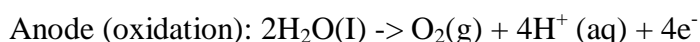

2. Calculate the number of moles of electrons that were transferred.

Knowing:

- Amperes X time = Coulombs
- 96,485 coulombs = 1 Faraday (F)
- 1 Faraday = 1 mole of electrons

Example:

o  $60 \text{ (amps)} * 3600 \text{ (seconds)} = 216,000 \text{ (coulomb)}$

o  $216,000\text{C} * \left(\frac{1\text{F}}{96,485\text{C}}\right) = 2.239\text{F}$

o  $2.239\text{F} * \left(\frac{1 \text{ mole e}^-}{1\text{F}}\right) = 2.239 \text{ mole e}^-$

3. Calculate the moles of hydrogen and oxygen produced using the number of moles of electrons calculated and the stoichiometries from the balanced half-reactions. According to the equations, 2 moles of electrons produce 2 mole of H<sub>2</sub> and 4 moles of electrons produce 1 mole of O<sub>2</sub> gas

$$2.239 \text{ mole e}^- * \frac{2 \text{ mole H}_2}{2 \text{ mole e}^-} = 2.239 \text{ mole H}_2$$

$$2.239 \text{ mole e}^- * \frac{1 \text{ mole O}_2}{4 \text{ mole e}^-} = 0.560 \text{ mole O}_2$$

4. Calculate the volume of each gas using ideal gas law ( $V=nRT/P$ ).

Where n: number of moles.

R: Boltzmann constant = 0.08206 (L atm/mol K)

T: temperature in kelvin.

• Volume of Hydrogen gas:

$$\text{○ } \frac{(2.239 \text{ mole H}_2)(0.082 \text{ L} \frac{\text{atm}}{\text{mole K}})(298\text{K})}{1 \text{ atm}} = 54.7 \text{ L of H}_2$$

$$\text{○ } \frac{(0.56 \text{ mole O}_2)(0.082 \text{ L} \frac{\text{atm}}{\text{mole K}})(298\text{K})}{1 \text{ atm}} = 13.6 \text{ L of O}_2$$

These calculations have shown that for a current of 60 amps during a period of 1 hour, the electrolysis of water yields 54.75 liters of hydrogen gas and 13.69 liters of oxygen gas.

For our design we are going to implement a Square Cell System. The stainless steel tubes with a negative charge will be connected to the negative pole of the battery and the positive will be connected to a relay, this will give us an on/off control of the system while we drive. For these connections we are using 4 gage cables to reduce electric resistance. To avoid all possible losses the vessel should be placed close to the car battery. An ammeter, as well as a fuse are part of the system, this will help us to monitor and for the system safety respectively

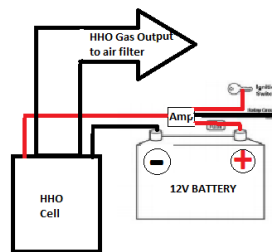

FIG. 5

A reservoir tank will be implemented to maintain the level of water required inside the vessel. This will be done automatically with a pump connected to the tank that's regulated by a level sensor placed inside the vessel. The output of the HHO generator cannot be connected directly to the air intake manifold of the car. For safety reasons is important to use an apparatus called "bubbler" between the HHO generator and the intake of the car as shown in the figure below. The bubbler is closed container full of water that will help us avoid any back fire from the engine to enter our generator, this can cause an explosion.

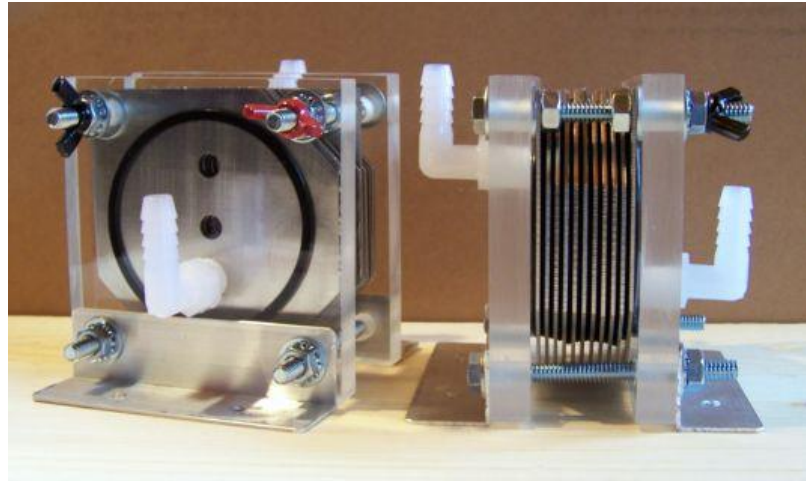

FIG.6. Bubbler



### **Plan for Test on Prototype**

The prototype is small-scale hydrogen generator. In the device, each plate is assigned to a cathode and an anode. Using electrolysis on water the cathode side will produce hydrogen gas ( $H_2$ ), and anode side will produce Oxygen gas ( $O_2$ ). To make sure the generator is working we will use a regular car battery of twelve volts.



**FIG. 7** Prototype

### **5. CONCLUSION**

In the design of our hydrogen generator we are trying to increase fuel efficiency while providing additional power. The hydrogen cell produces oxygen and hydrogen from water through electrolysis. We are trying to minimize the cost by using widely available materials. However, the cost may go up based on the results of different tests and the goal that we want to reach. Our project will benefit the environment and society. Since implementing the hydrogen generator will produce less carbon dioxide to the atmosphere. Therefore it will reduce greenhouse gasses.

Hence, less effect on global warming on the long run. Moreover, since implementing a hydrogen generator will provide more fuel efficiency, it will save money for people who will use our product.

## 6. REFERENCES

- [1] Fulton J, Lynch F, Marmora R. Hydrogen for reducing emissions from alternative fuel vehicles SAE paper 931813; 1993.
- [2] Chemistry Perdue. Electrolysis. <http://www.chem.purdue.edu/gchelp/howtosolveit/Electrochem/Electrolysis.htm>
- [3] Boretti A. Advance in hydrogen compression ignition internal combustion engines. Int J Hydrogen Energy 2011.
- [4] U.S. Department of Energy, Hydrogen analysis resource center, accessed on Feb. 3rd 2009. URL <http://hydrogen.pnl.gov/cocoon/morf/hydrogen>
- [5] Verhelst S, Sierens R. Aspects concerning the Optimization of a Hydrogen Fueled Engine. Int J Hydrogen Energy 2001.

## PSYCHOLOGICAL COMPLEX IN THE MILITARY – SOURCES AND MANIFESTATIONS

**Ana-Maria MIHALEA**

”Henri Coandă” Air Force Academy, Braşov, Romania

**Abstract:** *Although the military personnel are evaluated regularly for medically appropriate standards, it is possible for individuals to develop mental complexes, many of them originating in childhood. Identification and characterization of psychological complexes developed in people in the military is a topical issue since military activity requires compliance with rules, promotion of attitudes based on moral values such as honesty, loyalty, courage, dignity and patriotism.*

*A psychologically complex behavior manifests as images, emotions that hinder adaptation to ever new situations and problems specific to requirements of military life. At one point, people involved in military activities can develop individual and collective frustrations, which, accumulated unconsciously may generate power centers that will develop into mental complexes. The ideo-affective complexes are the most common developed complexes in people, which are real barriers to effective communication in the military organization.*

**Keywords:** *complex physical, behavioral, military environment, ideo-affective complex.*

### 1. INTRODUCTION

The present work is a theory for achieving a case study on the identification and characterization of psychological complexes developed by people in the military. After the etymological explanation of the term complex / complex psychic this has conducted to a systematic review of the types of complex mental, aiming to present them on the following coordinates: defining the particularity dominant, accurate feelings directly expressed to the complex at adulthood, manifestations and causes appearance of the complex.

The last part presents a selection of reactions and behaviors detected on people with complexes in the military and some suggestions to solve these mental states due to various complexes. The originality lies in the synthesis of work done in achieving a stringency scientific selection of the information.

### 2. ETYMOLOGY OF THE ‘COMPLEX’ / ‘PSYCHOLOGICAL COMPLEX’ TERMS AND THEIR SEMANTICAL DEVELOPMENTS

As DEX, "complexes are a set of unconscious tendencies, formed in childhood, based on certain family and social relationships that determine the subsequent behavior of the person."

In current sense, a "complex" means a sense of guilt, inferiority or, in speech usual term; this word can have negative connotations, being associated when meaning is not known with "weakness".

Etymologically, the term comes from the Latin "complexus" which means "connection, chaining, joining" the specific language psychoanalytic, denoting "a whole systematized representations and memories with strong value or significance emotional, assembly partially or totally unconscious" (cf „Dicționarului de psihologie”, autor Paul Popescu – Neveanu, Ed. Albatros, Buc.,1975).

"Psychologically complex," the term belongs to Carl Jung to designate "a mental formation determined as a conglomeration of ideas, emotions, affections and impulses which manifest themselves apart from the motive of self control. Complexes structure the human mind and they do not always have a morbid feature. („Dicționar de termeni, noțiuni și expresii în Psihanaliza, w.w.w.psihanaliza.org/termeni.html). According to the "Dictionary of Jungian terms," "it represents a complex group of ideas and unconscious representations emotionally invested." To the psychological term "complex" is attributed mostly a negative meaning, denoting "a combination of impulses: it is an organization that we need for our daily action" (Jues 1998 Albu, 2002). In psychoanalytic terminology, psychologically complex designates "a combination of personal traits, desires, emotions, feelings, attitudes contradictory emotional, always practically unconscious, everything organized in one indissoluble whole, an integral part of the personality". In short, it is "an assembly of elements with great emotional impact organized around an unconscious organizing core"(idem).

Mental complexes appear as an "acquisition of the person in the unconscious sphere and it manifests externally in a symbolic way, their significance having a formal aspect, that is superior in organizing instincts". (Gianina – Athala Ganda, "Complexele ideofective – bariere ale comunicării eficiente în organizația militară").

The term "complex" must not be mistaken with "a pathogen core that should be deleted" because it would lose of sight the function that structures the human development in certain moments, or complexes, in particular the Oedipus complex.

Jung speaks of "affective complexes" that belong to the individual unconscious; he also uses the phrase "constellated content", responding "to some complexes that have their own specific energy." Also, in 1933, he was saying that complex is "a nuclear element, a carrier of meanings"; stolen from conscious will, it is unconsciously and uncontrollably; a number of associations in this core are, on the one hand, the result of the personal innate disposals and, on the other hand, are the result of individual experiences conditioned by the external environment. In the first case there is a potential state of the complex, in the second, a current state of the complex.

The complex can be also understood as a segment of conduct marked by trends, representations about inner self, a disconnected segment from the reflective conscious ego and without a unified significance in relation to the actual existence of the subject.

The subject may feel complex depending on the nature of the information received and processed in one or more plans: intellectual, social, affective, constitutional.

The complexes consist of: representation, intellectual elements, and elements of sensory perception, motor factors and emotional elements. The origin of complexes is in the first incidents of independent life of the individual during childhood (0-10 years), period of time that is marked by a strong emotional reception.

Everyone has complex understood as "core mental reflex responses to different experiences that have left emotional imprint. So, complexes are combinations of emotions, thoughts, representations, expectations grouped around a common theme that springs into action autonomously, escaping conscious control".(Roxana Nourescu, "Complexele psihologice și importanța lor în viața de zi cu zi").

There are as many types of complex as many human experiences are, reasons underlying their being universal. In the military environment, subject to strict rules of conduct, hierarchically subordinated, can be identified complexes related by interaction with superiors, related by the need for recognition from others, intelligence complexes, superiority or inferiority complexes etc. CG Jung described several complex categories that are based on a certain archetypal reality (ie start from universal human experiences: parental complexes-maternal and paternal-, child complex, the old wise complex, fraternal complex, the hero complex, Shadow, Animus and Animate).

The complexes are part of conscious and unconscious mental organization and are in various degrees of relationship with the Self, understood as the center of conscious personality. When enabled, a complex throws the person in the past, in the original experience, and force the person to meet today with the same kind of emotional reaction when the complex appeared. For example: a parental complex can activate when an adult is at work, around superior etc. If infantile need for attention and approval was not satisfied in the relationship with parents, will persist in adulthood and likely will be reactivated in susceptible relations, being tempt to repeat the dynamic parent - child. An inferiority complex will cause the individual to systematically compare with others and always find that "something" is missing, in order to be satisfied etc.

Most complexes are formed in interaction with parents because within these relationships the individual develops himself, other complexes can be added throughout life.

The complexes have a negative effect, if they determine the individual to relive the same inner drama, old, available for automatic emotions, without being deeply anchored in the present moment. Some, however, may have a positive effect, for example Anima complex, which includes affective and cognitive representation of women idea and will help the man to relate to the opposite sex, giving a general perspective of what may be the person in front. Even detected, complexes do not disappear, they remain in the structure of the individual psyche, but once understood, their relationship to ego change.

### **3. TYPES OF COMPLEXES (CLASSIFICATION BY DIFFERENT CRITERIA)**

- A. After C.G.Jung complexes are grouped into:
  - a) complexes apart from conscious ( " sick complex " of the ill psyche);
  - b) complexes included in the unconscious ( "healthy complex" of the healthy psyche).
- B. After origin:
  - a) complexes bound to events/conflicts in infancy;
  - b) complexes bound to current events/conflicts.
- C. After nature:
  - a) morbid complexes;
  - b) healthy complexes.
- D. After their mode of expression, in relation to the circumstances:
  - a) negative;
  - b) positive.
- E. I. Popescu - Sibiu (1998) distinguishes the following types of settings:

1. Ideo-affective complexes of unconscious:
  - object complexes: the Oedipus complex/Electra complex; Cain complex/Oreste complex; spectacular complex/to be seen, to know everything, to see, to hide);
  - Ego complexes: inferiority complex/superiority complex; castration complex/ Diana complex, Narcissus complex;

2. Spiritual complexes (of conscious or moral consciousness).

F. After R. Mucchielli, the most common complexes are:

- a) the abandon complex;
- b) the complex of fraternal rivalry;
- c) the insecurity complex (uncertainty);
- d) castration complex or self-asserting in sexual plan;
- e) complex of guilt;
- f) inferiority complex;

Based on subjective criteria (established by the individual himself) or collected from the social environment, any man can develop "tension" which, in fact, lead to the establishment of these ideo-affective complexes. In relation with the intellectual development and emotional intelligence, a person can reach the stage of inferiority feeling, of culpability, of abandonment, of rivalry, or can reach the level of a ideo-affective complex.

The complex, usually, is "a barrier to exercise plenary personality;it integrates into the personality structure, directing its expression. "(Gianina – Athala Ganda, "Complexele ideo-afective ale comunicării eficiente în organizația militară", p.2.)

#### **4. TYPES OF BEHAVIOR AND RESPONSES OF INDIVIDUALS WITH COMPLEXES**

The most common types of behavior and responses of individuals that display complexes include:

- a) manifestation of sensations and feelings of fear, insecurity, helplessness;
- b) elimination of these states by aggression;
- c) tendency to assert superiority when they feel inferiority;
- d) seek to gain power when they have the feeling of helplessness;
- e) will try to dominate if they feel dominated;
- f) trying to attract attention to themselves when they feel abandoned;
- g) when they feel abandoned, sometimes, gives exaggerated attention and affection of others;
- h) in moments of tension or anxiety, some individuals accuse somatic disorders, becoming cautious and stingy;
- i) unsafe persons joining influential people;
- j) individuals who may manifest inferiority complex become hyper-authoritarian, tyrannical, with aggressive behavior towards subordinates;
- k) persons with low self-esteem tend to demonstrate what are smart, boasting all sorts of achievements;
- l) some individuals blame the others for everything, even for trivial things when they feel guilty;
- m) individuals who have "inferiority" defects become obsessive by impeccably looks etc.

**5. SUGGESTIONS FOR SOLVING SELF CONFLICTS (TRIGGERED BY COMPLEX) (after Geanina-Athala Ganda, „Complexele ideoafective-bariere ale comunicarii eficiente in organizatia militara”):**

1. "The man must realize and accept reality exactly as it is;
2. To seek inner peace;
3. To seek compensation mechanisms, which does not "hit" on the other;
4. To find their inner power to manifest one's feelings, to express their points of view and thoughts;
5. To relax, to find pursuits that do not allow him to reconsider the real or imagined problems, to distinguish itself by making original products, to take responsibility;
6. To affirm by creating original products, to take responsibility;
7. To achieve something to represent him;
8. To support insecurity, uncertainty;
9. Do not be afraid of novelty, the unknown risk;
10. To learn to dare, to confront, experience;
11. To acknowledge the specifics of human relations existing in the workplace;
12. Let's look at things and people as they are, because nobody and nothing is perfect, everything is relative. "

**CONCLUSIONS**

Mental complexes are part of conscious and unconscious mental organization and are in varying degrees of relationship with one's Ego, understood as the center of the conscious personality. When activated, a complex throws the individual in the past, into the original experience and makes it respond with the same type of emotional reaction as at the moment when it appeared.

Complexes have a negative effect if they make an individual relive the same old inner drama, at the disposal of some automated emotions, without being truly grounded in the present moment.

Not even the detected complexes do disappear; they remain in place, as the structure of the individual's psyche, but once understood, their relationship with the ego change.

An inferiority complex will cause the individual to compare systematically with others and always find it lacks 'SOMETHING' to be satisfied.

There are as many types of complexes as the amount of human experiences; the reasons for their existence being universal. In the military environment, subjected to strict rules of conduct, hierarchically subordinated, there can be identified complexes related to interaction with superiors, with the need for recognition from others, intelligence complexes, inferiority or superiority complexes.

In order to identify the existing mental complexes in people from the military it is necessary to deepen their specific traits, the existence of a scientific support being inextricably linked to this intention. I believe that finding the mental complexes associated with some types of reactions and behaviors is absolutely necessary, especially with regard to the military personnel who participate in missions that take place both in the country and abroad.

Even if military people undergo some rigorous medical tests, according to the recruitment conditions, there is the possibility of their developing psychological complexes; their cause may be inter-personal relationships (superior-inferior) rigorous program, regulatory compliance, etc., the military background being a trigger of complexes that originate in childhood, because the complex is an organized grouping of representations and memories with strong emotional value, partially or totally unconscious. From this point of view, psychological complexes structure all psychological levels: emotions, attitudes, behavior etc.

From a behavioral standpoint, psychological complexes, especially in the people of the military, constitute a strategy, a behavioral algorithm of some kind; thus, their knowledge being imposed as an intrinsic reality.

## REFERENCES

- [1]Albu, Gabriel: „In cautarea educatiei autentice”, Ed.Polirom, Iasi, 2002;
- [2]Enachescu, Constantin: „Tratat de psihanaliza si psihoterapie”, EDP, BUC., 1998
- [3]Enachescu, Constantin: „Tratat de psihologie morala”, Ed. Tehnica, BUC, 2002;
- [4]Gianina-Athala Ganda: „Complexele ideoafective – bariere ale comunicarii eficiente in organizatia militara” – w.w.w.scoalarosu.ro/RO – FILES/Info – pub/revista\_pedefe/11/complexele % 20 ideoafective.pdf
- [5]Nourescu, Roxana: „Complexele psihologice si importanta lor in viata de zi cu zi”;
- [6]Popescu – Neveanu, Paul: „Dictionar de psihologie”, Ed.Albatros, Buc, 1978;
- Roco, Mihaela: „Creativitate si inteligenta emotionala”, Ed.Polirom, Iasi, 2001;
- [7],„Dictionar de termeni, notiuni si expresii din psihanaliza”, w.w.w.psihanaliza.org/termeni/html;
- [8],„Dictionar de termeni jungieni”, w.w.w.psihanaliza.org/junc/dictionar/html;
- [9][https://www.roxananourescu.ro/articole/57\\_complexe\\_psihologice\\_si\\_importanta\\_lor\\_in\\_viata\\_de\\_zi\\_cu\\_zi.html](https://www.roxananourescu.ro/articole/57_complexe_psihologice_si_importanta_lor_in_viata_de_zi_cu_zi.html).
- [10][www.scritub.com/sociologie/psihologie/COMPLEXELE\\_ARHETIPURILE\\_SI\\_SIM95156.PHP](http://www.scritub.com/sociologie/psihologie/COMPLEXELE_ARHETIPURILE_SI_SIM95156.PHP)



## MICROWAVE LANDING SYSTEM

**Adrian-Florin ARTENIE**

“Henri Coanda” Air Force Academy, Brasov, Romania (artenie\_adrian@yahoo.com)

**Abstract:** *The microwave landing system has been adopted by ICAO as the standard precision approach system to replace the Instrumental Landing System (ILS) because of its much smaller antennas, a higher frequency signal, a flexibility way of placing on the airport, an electronically “offset” and more channel available, eliminating the broadcast interference problems. The system provides information about approach and back azimuth, approach elevation, range guidance, data communications and some additional information as condition of the runway or system category. The information are obtained by an onboard antenna that measure the time between two passages of an oscillating lobe of a high frequency signal. The system has a wide coverage sector around the airport both horizontally and vertically, in elevation up to 15° and to at least 6km, 40° on the either side of the runway centerline and range to at least 37km.*

**Keywords:** *microwave, guidance, navigation, airport.*

### 1. INTRODUCTION

The Microwave Landing System (MLS) is an alternative to the ILS to overcome his disadvantages and provide a greater flexibility to its users. The MLS is a radio guidance system that provides precision navigation information about glide path, aircraft position and various other important data only in the area of the final approach.

The system works with a microwave beam that scans a wide sector both in vertical as in the horizontal plane and provides accurate information about elevation, azimuth angle and range both for approaching aircraft as for those that take-off. [1]

### 2. DESCRIPTION OF MLS

**2.1 MLS composition.** The main functions of the Microwave Landing System are approach and back azimuth, elevation, distance and data communications.

The MLS integrate both ground pieces of equipment that are divided into the protractor components and the rangefinder components and an on board equipment. The information about the angles of the approach course, descent, flare and the course of an unsuccessful approach are acquired through an onboard antenna or the aircraft itself by measuring the time between two passages of an oscillating lobe of a high frequency signal. The ground equipment consists in the basic configuration of an Azimuth Transmitter with an added DME rangefinder, or even a more precise DME/P, in close distance of a course transmitter and near an elevation transmitter which provides highly accurate range information. [5]

Compared to the existing ILS system, MLS antennas are much smaller, because of a higher frequency signal. They also do not have to be located at a specific point at the airport, and could "offset" their signals electronically. The MLS take advantage because the station is mobile and can be deployed within hours. [5]

With the exception of the DME signals, all the other MLS signals are transmitted on a single frequency. Two hundred channels are available between 5031 and 5090 Megahertz. By transmitting a narrow beam widths 1-2° which sweeps across the coverage area at a fixed scan rate of 20.000°/s, it is calculated both azimuth and elevation by an airborne receiver which measures the time interval between sweeps. [3]

The following Figure 2.1 presents the on board equipment that is used to measure and indicate the path elements for approaching, the channel number and the azimuth and glide path angles.

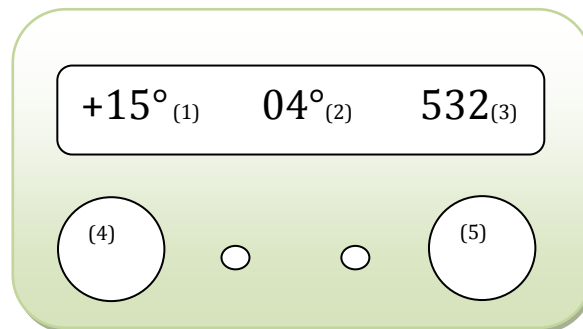
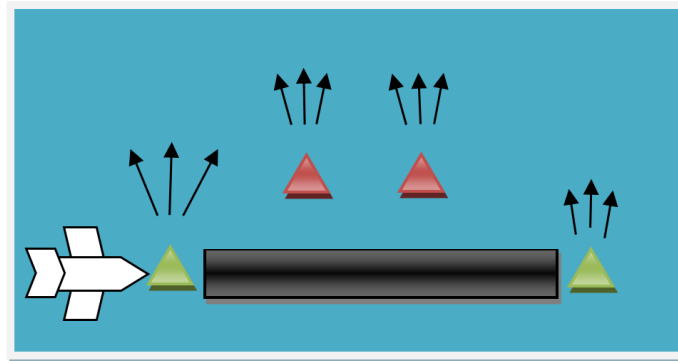

**FIG. 2.1** Airborne equipment



- 1 - Approach azimuth relative to runway centerline;
- 2 – Required glideslope;
- 3 – Channel number;
- 4 – Mode selector (Auto or Manual);
- 5 – Angle/Channel selector.

The following Figure 2.2 presents the general architecture of the ground stations that consists in azimuth and elevation systems and an additional DME.

Azimuth radio beacons works successive and the synchronization signals are generated by the equipment disposed on the control point. Both azimuth and elevation transmissions are radiated on the same frequency with an arranged signal time. The MLS ground system comprises azimuth and elevation angles which data functions are frequency shift key modulated and scanned in the runway area. The same equipment transforms the additional data into modulator signals to provide information about weather data and runway conditions as wind speed, cloud base or icy runway. [1]



**FIG. 2** MLS ground system composition.

-  - Approach azimuth and DME antennas
-  - Elevation + Flare antenna

**2.2. Time Referenced Scanning Beams.** The Microwave Landing Systems can be classified by the type of the informational parameter in temporary and frequency signal systems, TRSV (Time Reference Scanning Beam) and DMLS (Doppler Microwave Landing System) belongs to these groups.

For the TRSV, MLS uses 5GHz transmitters at the landing place which employs passive electronically scanned rays to send scanning beams towards approaching aircrafts. Every aircraft that enters the scanned volume and it's equipped with a special receiver will calculate its position by measuring the arrival times of the beams.

In addition to the MLS receiver and antenna, this complement contains a guidance computer for segmented or curved approaches. The crew must insert the way point information for a segment on-line during the approach. The way point data include the bearing, elevation, and distance of the way point from the MLS datum point. When the system is engaged, the computer calculates a course from the aircraft's present position to the way point. The system block diagram is shown in Figure 2.3. The crew interface for the way point entry is a modified VHF navigation control panel allowing entry of the bearing, elevation, and range, and selection of the forward or back azimuth antenna. Steering deviation signals are fed to the autopilot and the instruments. The way point's course and range are indicated by the course arrow and the left DME readout of the HSI. The course and range to the MLS datum point are indicated by the second course arrow and the right DME readout. [4]

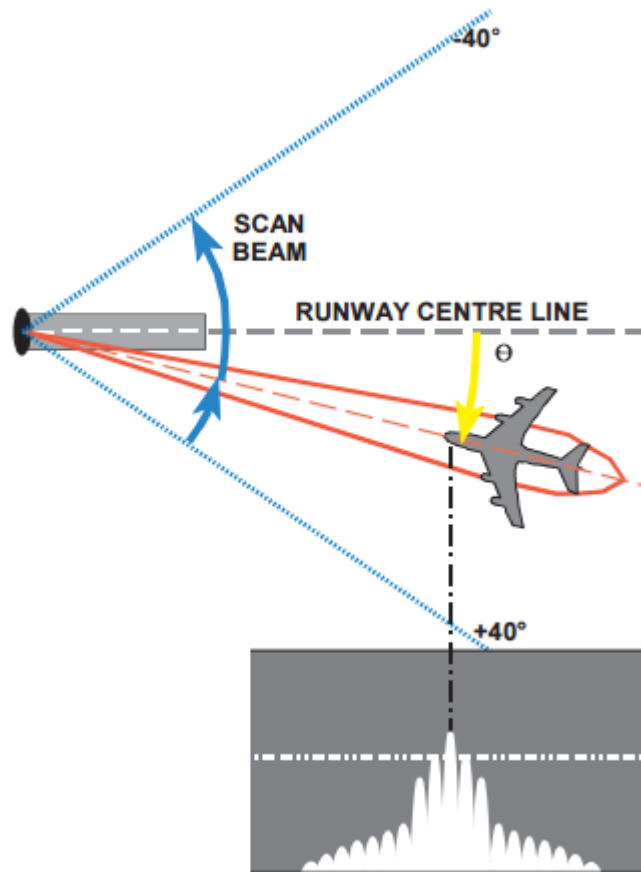

FIG. 2.3. The horizontally sweep that provides a position line in azimuth [7]

**2.3 Multiplexing.** This technology allows the total bandwidth to be divided into a series of sub-bands and allows every piece of information from each of the azimuth and elevation beams to be obtained from signals on the same frequency as in Figure 2.4. After one piece has been received it is used and stored until it is replaced. A pulse is detected each time the beam sweep past the aircraft and every piece of information requires a very short time to be registered. The total time taken to receive every piece of information required for the MLS system to function in this way is about 84 milliseconds. This is divided into specific periods or bands in which the individual pieces of information are transmitted (and received). This is multiplexing.

In addition to guidance information, auxiliary information is also sent during the multiplex transmission. This includes the station identification, safety information such as the minimum safe glideslope angle, and more other information such as system condition, weather and runway conditions that can be displayed in the cockpit.

Beams can also scan in the opposite direction from the approach path in order to provide guidance to aircraft in the missed approach segment and useful information for the aircrafts after they take-off. The time between emitted signals isn't equally divided, three elevation signals and one azimuth signal are received the same time and this rapid change indicates a great danger. There are 40.5 elevation and 13.5 azimuth scans every second. [7]

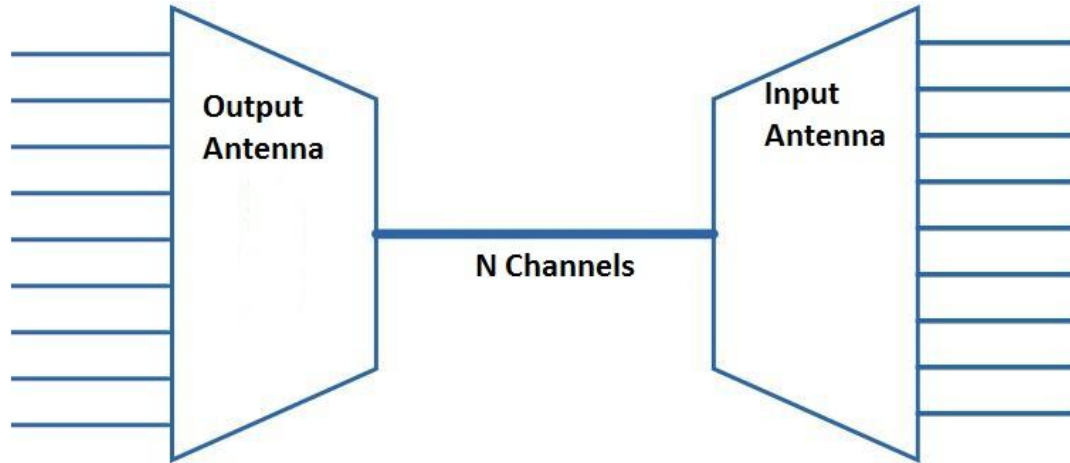

FIG. 2.4 Multiplexing

### 3. MLS PRINCIPLE OF OPERATION

**3.1 Frequencies.** This system works on 200 channels in the band between 5031.00 and 5090.70 Megahertz with a space of 300 Kilohertz apart. It is used only 1 channel for all of its transmissions except the DME, which frequencies are automatically selected. This means a considerable reduction in air traffic delays because the air traffic controller clear the aircrafts for curved approach paths with a straight final segment.[2]

**3.2 Azimuth Coverage.** In the approach segment, located about 300 meters beyond the runway, the horizontal area scanned by the guidance beams is  $+40^\circ$ , each side of the centerline, out to 30 nm from the station as Figure 3.1. The system has an accuracy of  $\pm 4$  meters. On vertical plan, the beams give guidance between  $0.9^\circ$  and  $20^\circ$  above the horizontal, up to 20,000 feet (6km), although the guidance may be restricted to a maximum elevation of  $7.5^\circ$ . The missed approach segment is  $20^\circ$  each side of the centerline, and vertically from  $0.9^\circ$  to  $15^\circ$ , out to 10 nm from the station and up to 10000 feet. [6]

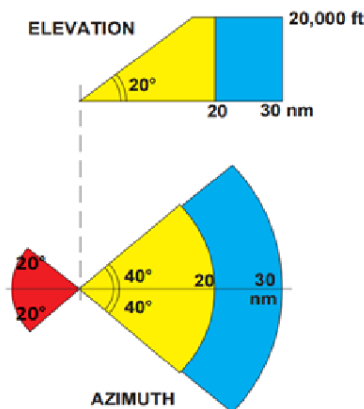

FIG. 3.1 MLS Azimuth Guidance Horizontal and Vertical Coverage [7]

**3.3 Elevation Guidance Coverage.** The specification for elevation coverage is almost the same. The elevation transmitter has an accuracy of  $\pm 0.6$  meters. It covers the approach sector out to at least 20 nm, and within a horizontal angle of at least  $10^\circ$ . In elevation, the minimum coverage is from  $0.9^\circ$  to  $7.5^\circ$  above the horizontal, although it should cover the whole of the azimuth approach sector, Figure 3.2. [6]

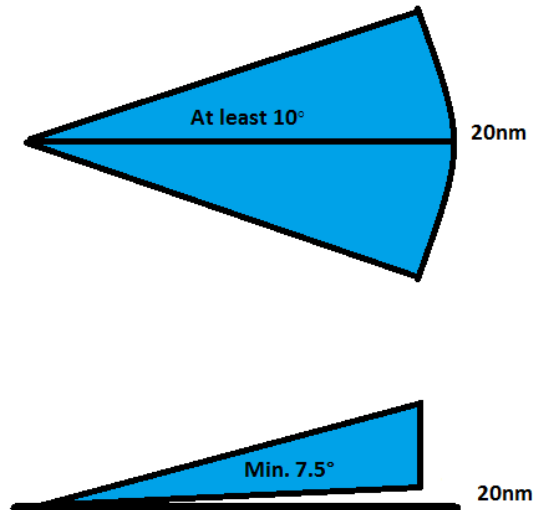

FIG. 3.2 MLS Elevation beam horizontal and vertical coverage

**3.4 Range guidance.** The range between an aircraft and the ground station is provided by the Distance Measuring Equipment (DME/P) that is included in the MLS. This equipment allowed MLS to guide approaching aircrafts extremely accurate. Like the DME stations used for ILS ranges, the DME/P is electronically adjusted to give ranges from the runway. The DME/P provides direct distance between aircraft and ground equipment instead of horizontally distance. The beacon transponders works in the frequency band 962 to 1105 Megahertz only when it appears interrogation from the aircraft to the ground Transponder. The aircraft emits a series of pulse-pairs with known time between them that form an authentication code for every aircraft, in that way DME can provide range information for 100-200 aircrafts at a time. [8]

**3.5 Data communication.** The transmitted data can contain basic and auxiliary data words. The information is transmitted on the runway sector both in approach landing path as in the missed approach segment. Basic data content include station identification, DME/P channel, ground equipment performance and exact locations of azimuth, elevation and DME/P station. Auxiliary data content include waypoint coordinates, location of the MLS, runway and weather condition. [8]

## 4. SYSTEM ACCOMPLISHMENTS

**4.1 Accuracy landings.** The MLS provides a 95% lateral and vertical accuracy for the aircrafts in the area of the final approach, as ICAO prescribed. The system also provides information shortly after take-off. The system works with a microwave beam that is transmitted towards the both side of the runway area and scans the sector both in the horizontal as in the vertical plane. [2]

**4.2. System placement.** An aircraft in the approach sector receives the signal from the ground equipment and with the help of this beam evaluates its location in space. The aircraft position is therefore determined both in the horizontal direction of approach as in the vertical plane, in whatever point of reach of the scanning beam. Because the microwave signals are radiated into the space of approach in a given time and it is not spread out over different directions, no signal interruption results from various obstacles or terrain protrusions as it was with the ILS system. The MLS system can thus be situated also in developed areas, where an ILS system could not be set up. An onboard computer enables to solve the approach maneuver from a random direction, for variously oriented runways, even along a curved or bend landing trajectory. The MLS system is approved by the ICAO for every three categories of an accurate landing approach. [1]

**4.3 MLS advantages to ILS.** ILS has some limitations to MLS which prohibit or restrict its use in many circumstances. A few ILS basic limitations are: site sensitivity and high installation costs; single approach path; multi path interference; channel limitations, only 40 channels.

MLS not only eliminates these problems, but also offers many advantages over ILS including:

1. Availability of 200 channels; Provide landing path information to a large number of aircrafts;
2. Eliminate the ILS/FM broadcast interference problems;
3. Provide information on every weather conditions; Elimination of service interruptions caused by snow accumulation;
4. Provide accurate guidance to small landing areas as for heliports;
5. Accommodation of both segments and curved approaches;
6. Improved guidance quality with fewer flight path corrections required;
7. Provision of back-azimuth for missed approaches and departure guidance;
8. Lower site preparation, repair, and maintenance costs. [7]

**4.4 MLS disadvantages.** The equipment installation is very expensive and also a new alternatives as GNSS are emerging as main system to be used for civil aviation, GPS-Global Position System, usage is meant to rule the future of radio-navigation systems. By the time MLS was developed, the GPS was so advanced that in many countries further installation of MLS was abandoned. In the United States the last two MLS flight procedures were eliminated in 2008. But in some European countries where it is bad weather conditions and uneven terrain, the MLS has been adopted as a replacement of ILS. [2]

## CONCLUSIONS

In conclusion MLS provide three-dimensional navigation guidance accurate enough for approach and landing maneuver on any weather conditions. The system has a wide scanning area around the runway and work on 200 channels without any interference. This system has both on board and ground equipment. This system was initially designed to replace ILS because the latter has some limitations but because of the expensive replacement and appearance of a better system named GPS, the MLS was suspended from United States and now is used only by a few European Countries.

## REFERENCES

- [1]. Tooley M. [2011]. *Aircraft communications and navigations systems*. London. Routledge.
- [2]. *Radio navigation*. Nordian Aviation Training Systems.
- [3]. Moir I. and Seabridge A. [2006]. *Military avionics systems*. United States. American Institute of Aeronautics and Astronautics.
- [4]. Circiu I. [2006]. *Sisteme radioelectronice de aviatie si comunicatii*. Brasov. Editura Academiei "Henri Coanda".
- [5]. <http://www.microwave.landingssystem.com/>
- [6]. [https://en.wikipedia.org/wiki/Microwave\\_landing\\_system](https://en.wikipedia.org/wiki/Microwave_landing_system)
- [7]. <https://www.aircraftspruce.com/catalog/pdf/13-08721.pdf>
- [8]. <http://www.cfinodebook.net/notebook/avionics-and-instruments/microwave-landing-system>



STUDENTS' INTERNATIONAL CONFERENCE AFASTUD 2017  
19<sup>th</sup> Edition  
*COMMUNICATING ACROSS CULTURES*



ROMANIA  
“Henri Coandă” Air Force Academy  
160 Mihai Viteazul st. Brasov 500183  
Tel +40 268 423421  
[www.ahafc.ro/afastud/arhiva.html](http://www.ahafc.ro/afastud/arhiva.html)